

BIOINTEGRITY & BIOSTIMULATORY PROJECT STAKEHOLDER OUTREACH MEETING

December 22, 2016

CalEPA Building, Training Room 1, Sacramento

10:30-4:30 pm



CONTEXT FOR TODAY'S MEETING

- California State Water Board staff was directed to combine the Biostimulatory substances and Biointegrity projects for wadeable streams
- Governance of this process remains the same
 - We have merged the stakeholder advisory groups, kicking off the combined SAG today
 - An independent Science Panel will continue to provide ongoing peer review of science that will be used in policy development
- Technical team, led by SCCWRP, has been reformulating science plan to accommodate the combined projects

MEETING GOALS

- Provide an update on Water Board staff rationale for the combined biostimulatory and biointegrity projects
- Provide review and feedback on science supporting projects
 - Revised conceptual approach to science supporting the biostimulatory and biointegrity projects
 - Discuss work plan describing new technical element
 - Update you on work in progress
- Describe proposed changes to Science Panel composition reflecting Biostimulatory and Biointegrity projects
- Describe timelines for review of technical work elements, including timing of stakeholder and science panel meetings.

“Amendment to the Water Quality Control Plans for Inland Surface Waters, Enclosed Bays, and Estuaries of California to Establish a Biostimulatory Substances Objective and Program to Implement “Biological Integrity”

WHY COMBINE THE BIOINTEGRITY AND BIOSTIMULATORY/NUTRIENT PROJECTS?

Approaches to Develop Biointegrity and Biostimulatory/ Nutrient Projects Had A Lot of Commonality

- Chemistry alone insufficient to protect aquatic life; use biological indicators to assess beneficial use support
- Link biological indicators to stressor management
 - Causal assessment (biointegrity)
 - Default nutrient targets (biostimulatory)
- Use multiple indicators for more robust assessment
- Statewide consistency, with regional flexibility

Combine for “seamless” policy and streamlined implementation!

STATEWIDE BIOASSESSMENT PROGRAM AND STANDARDIZED INDICES MAKE A COMBINED POLICY FEASIBLE

- Standardized protocols and extensive sampling of benthic macroinvertebrates (BMI) & benthic algae
- Statewide scoring tools:
 - California Stream Condition Index (CSCI) for BMI (Mazor et al. 2016)
 - We are now supporting the development of a statewide algal stream condition index (ASCI)
- Assessment of nutrients and biostimulatory conditions relies on these standardized protocols for determining beneficial use support.

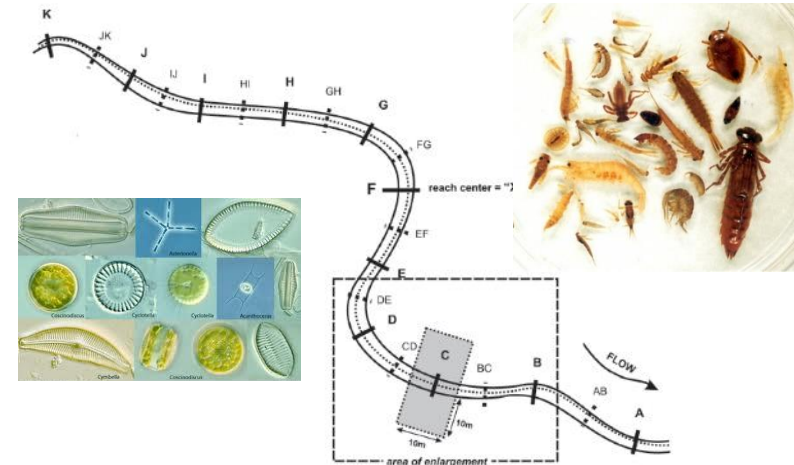

REVISED GOALS OF JOINT PROJECT

- Develop Objective for biostimulatory substances
 - Numeric or narrative
 - Protect aquatic life Beneficial Uses (BUs)
- Develop Implementation Program for biostimulatory substances
 - Source by source
 - Coordinated watershed approach
- Develop Statewide plan for assessing Biological Integrity in surface waters
- Establish methods to identify, maintain, and protect wadeable streams with high biological integrity.

CSCI AND ASCI BECOME THE SURROGATE MEASURES OF AQUATIC LIFE USE AND RELATED BENEFICIAL USES

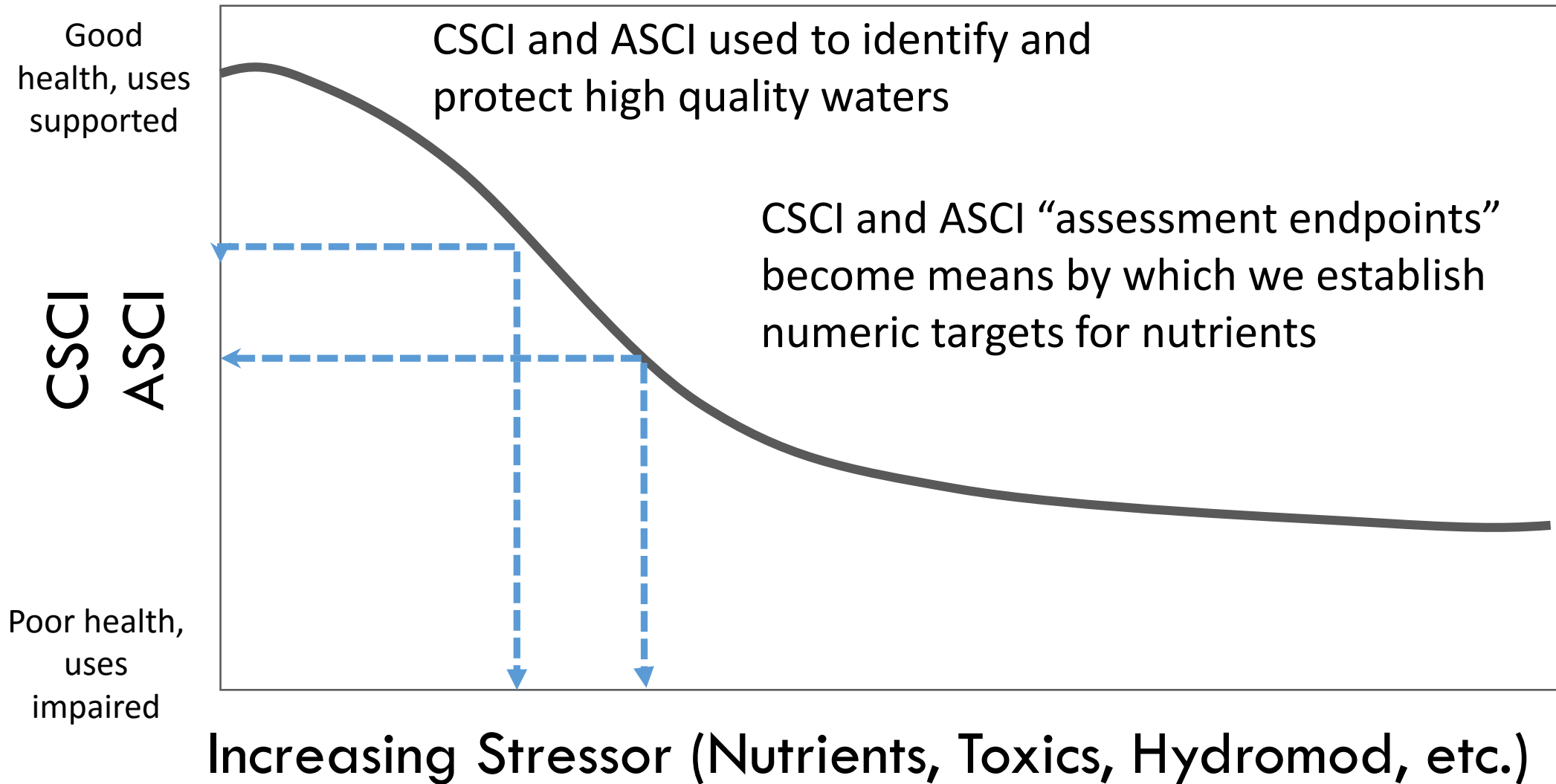

PREFERRED OPTION UNDER CONSIDERATION BY WATER BOARD STAFF

- Establish CSCI and ASCI “assessment endpoints” as primary lines of evidence to assess wadeable stream beneficial use support
 - Identify and protect high quality waters
 - Use CSCI and ASCI assessment endpoints to establish default nutrient targets (statewide), with option to refine under a “watershed approach”

PROJECT ELEMENTS (FROM CHARTER)

- Applicability
- Biostimulatory substances objectives
- Numeric translator?
- Implementation of objective and translator
- Policy to establish and implement biological assessment methods

FOCUS GROUP SUMMARY

- Ten Focus Group meetings were held during 2016
- Several groups were represented
- Purpose: Present options and gather feedback.
- 2 Elements presented
 - Objectives, Program of implementation/regulatory approach
- Staff is waiting final Policy direction from upper management but is proceeding with the science development.

TENTATIVE TIMELINE

Task	Description	Target Dates
Focus Group Outreach	Discuss with focus group stakeholders	February - June 2016
Project Outreach with Regulatory Group (RG) and Stakeholder Advisory Group (SAG)	Update the RG, SAG, and Science Panel members of the biostimulatory substances project and the RG and SAG of the bio-integrity project on technical science and the merging of the two projects.	December 2016
Early Public Outreach and/or Scoping Document and Meetings	Scoping Document and Meetings to satisfy the State Water Board's regulations implementing CEQA.	November 2017
Draft projects & SED	Develop Draft Biostimulatory Substances/Biological Integrity Amendment language & Draft Supplemental Environmental Documentation	Winter 2018
Public Comment	Release Draft Amendment and SED for public comment	Spring 2019
Public Hearing	Public Hearing to receive oral comments	Summer 2019
State Water Board Response to Comments	Develop written responses to oral and written comments	Fall 2019
Board Adoption	Board meeting to consider adoption	Winter 2019

QUESTIONS?

COMMENTS?

MEETING GOALS

- Provide an update on Water Board staff rationale for the combined biostimulatory and biointegrity projects
- Provide review and feedback on science supporting projects
 - Revised conceptual approach to science supporting the biostimulatory and biointegrity projects
 - Discuss work plan describing new technical element
 - Update you on work in progress
- Describe proposed changes to Science Panel composition reflecting Biostimulatory and Biointegrity projects
- Describe timelines for review of technical work elements, including timing of stakeholder and science panel meetings.

INTRODUCTIONS -TECHNICAL TEAM

SCCWRP

Martha Sutula

Eric Stein

Raphael Mazor

Susanna Theroux

Ken Schiff

CDFW

Pete Ode

Andy Rehn

Tetra Tech

Michael Paul

Benjamin Jessup

Jeroen Gerritsen

SCIENCE SUPPORTING COMBINED POLICY: OVERVIEW OF PRESENTATION

- Conceptual approach and update on existing work elements
 - Biological condition gradient model
 - Eutrophication synthesis
- Presentation of new technical elements
 - Algal Stream Condition Index (ASCI)

***WADEABLE STREAMS
SCIENCE PLAN SUPPORTING
BIOSTIMULATORY AND BIOINTEGRITY
PROJECTS***

(PLUS UPDATE ON EXISTING ELEMENTS)

WATER BOARD STAFF PREFERRED OPTION FRAMES A REFINED APPROACH TO SCIENCE

- Establish “assessment endpoints” for biological indices as primary lines of evidence to assess wadeable stream beneficial use support
- These assessment endpoints become goals used to establish numeric targets for....
 - Nutrients and intermediate eutrophication response indicators (now)
 - Other stressors (later)
- As part of combined Biostimulatory Policy, establish default nutrient targets statewide, with option to refine with “watershed approach”

CSCI AND ASCI BECOME THE SURROGATE MEASURES OF AQUATIC LIFE USE AND RELATED BENEFICIAL USES

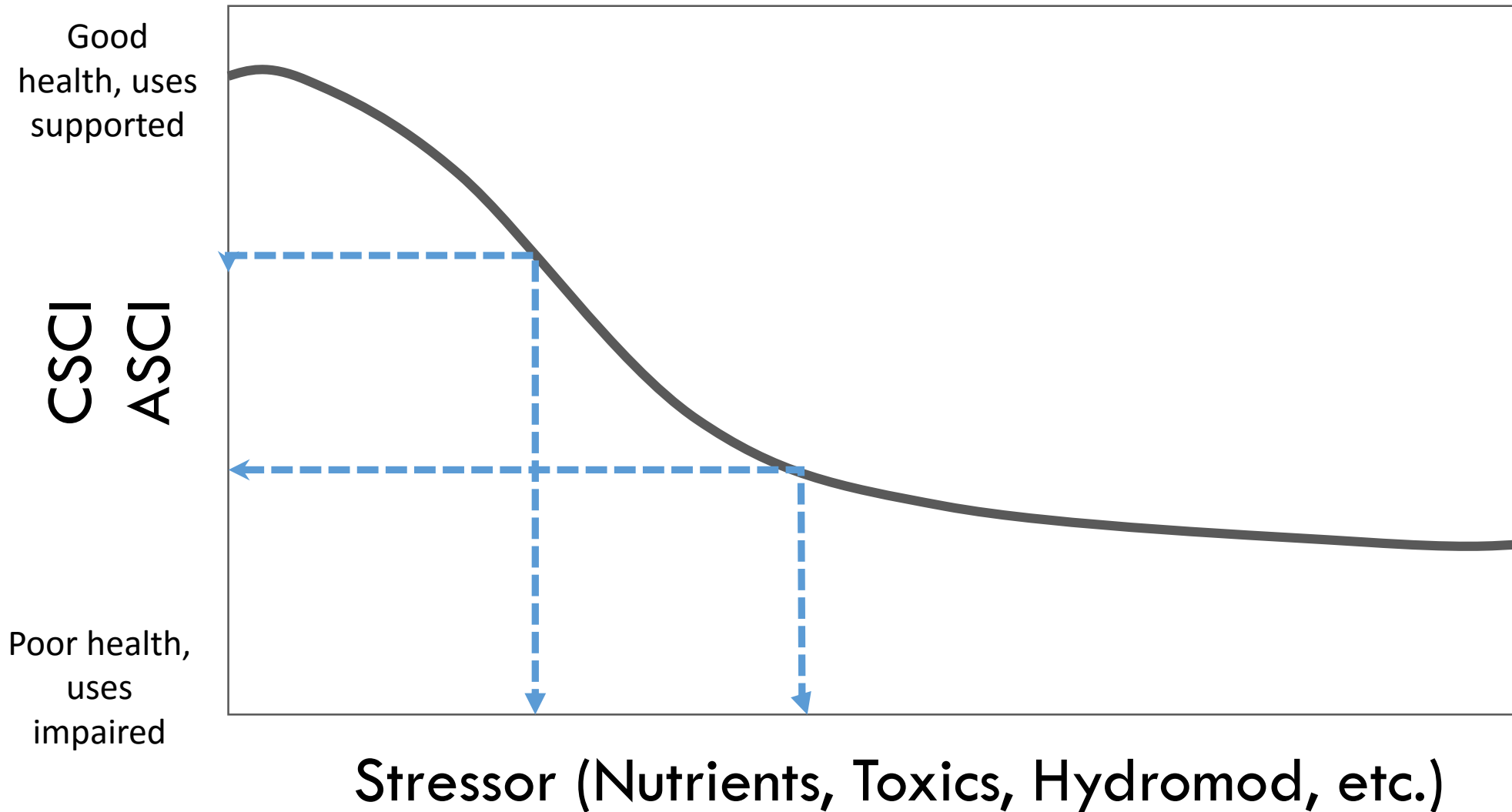

ELEMENTS OF THE SCIENCE PLAN

1. Conduct and synthesize science supporting development of numeric guidance for wadeable streams
 - 1.1 Develop biological indices indicative of aquatic life use support
 - 1.2 Determine the numeric range of biological indices that correspond to attainment of beneficial uses
 - 1.3. Determine the numeric range of stream nutrients and intermediate eutrophication response indicators that correspond to attainment of beneficial uses
2. Implementation plan technical support

ELEMENTS OF THE SCIENCE PLAN

1. Conduct and synthesize science supporting development of numeric guidance for wadeable streams

1.1 Develop biological indices indicative of aquatic life use support

1.2 Determine the numeric range of biological indices that correspond to attainment of beneficial uses

1.3. Determine the numeric range of stream nutrients and intermediate eutrophication response indicators that correspond to attainment of beneficial uses

2. Implementation plan technical support

THE CALIFORNIA STREAM CONDITION INDEX (CSCI) FOR BENTHIC MACROINVERTEBRATES

- A predictive index developed for consistent statewide applicability
- Calibrated with 472 reference sites from regions around the state
- Several benefits of a predictive index:
 - Establishes site-specific expectations, based on natural gradients (and expected reference) at each site
 - Consistent interpretation statewide, such that a score in SoCal means the same thing as a score in NorCal

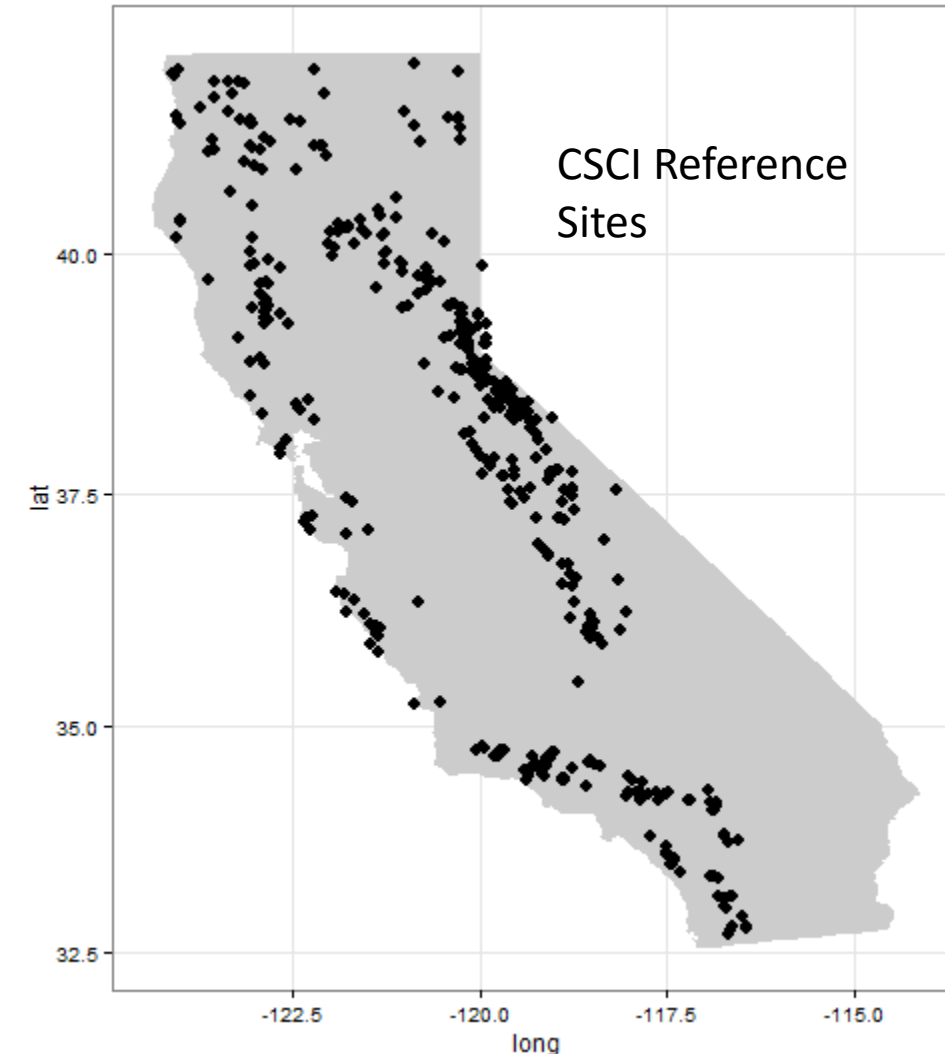

THE CALIFORNIA ALGAL STREAM CONDITION INDEX (ASCI) IS NOW UNDER DEVELOPMENT

- Approach consistent with that of CSCI
 - Calibrated with reference sites from all regions of the state
 - Establishes site-specific expectations
 - Statewide applicability/interpretability
- Complement to CSCI
 - Independent measures
 - because algae are less sensitive to habitat and more responsive to water chemistry

Susie Theroux's presentation will provide greater details

ELEMENTS OF THE SCIENCE PLAN

1. Conduct and synthesize science supporting development of numeric guidance for wadeable streams
 - 1.1 Develop biological indices indicative of aquatic life use support
 - 1.2 Determine the numeric range of biological indices that correspond to attainment of beneficial uses**
 - 1.3. Determine the numeric range of stream nutrients and intermediate eutrophication response indicators that correspond to attainment of beneficial uses
2. Implementation plan technical support
 - 2.1 Identify and map channels in developed landscapes

DETERMINE THE NUMERIC RANGE OF CSCI AND ASCI THAT CORRESPOND TO ATTAINMENT OF BENEFICIAL USES

Approaches that Could Be Used to Establish Assessment Endpoints

- **Percentile of Reference**
- **Biological Condition Gradient (BCG) expert synthesis**

CHOOSING ENDPOINTS BASED ON STATISTICAL DISTRIBUTION OF REFERENCE SITES

Establish BU attainment goal based on deviation from distribution of scores among “Reference” sites

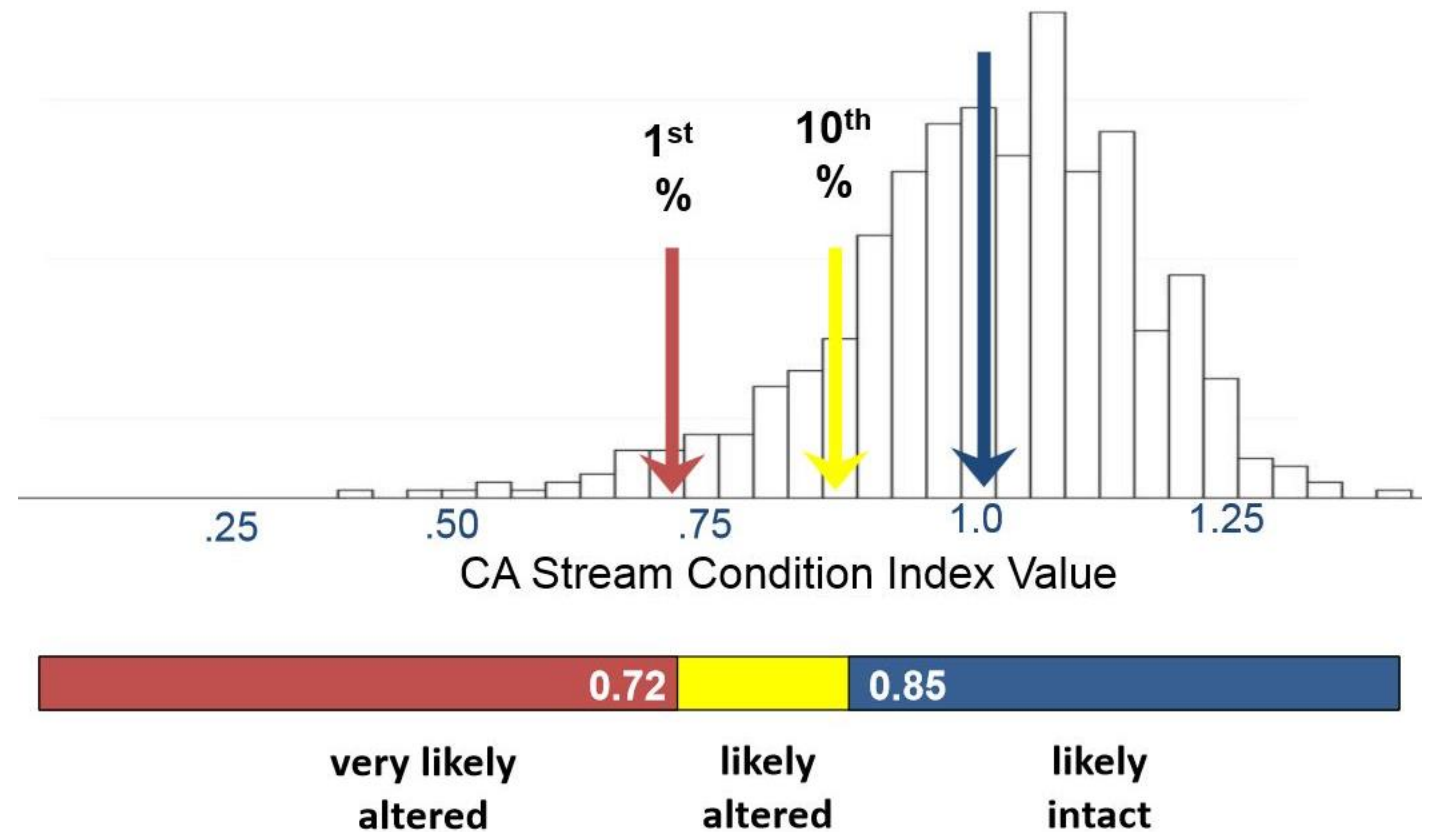

MOTIVATION FOR ALTERNATIVE APPROACH

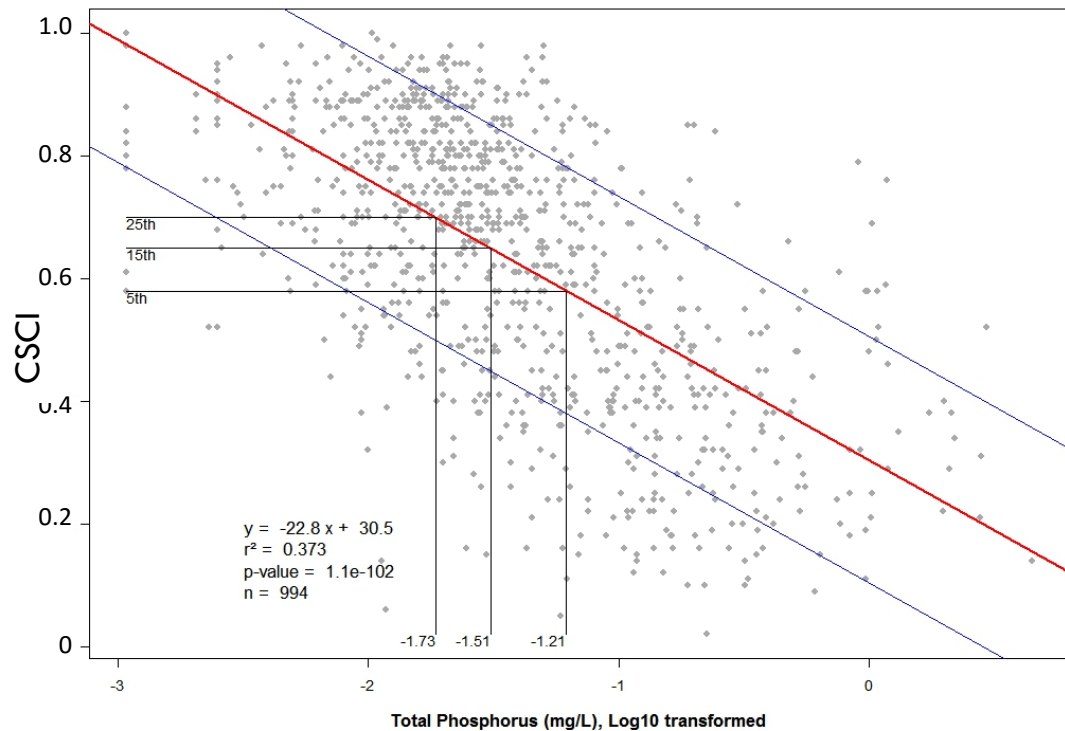

- “What does a value of 0.63 for the CSCI mean?”
 - It is 15th percentile of reference.
- “But, what does that mean ecologically?”
 - It is no longer like reference.
- “I think I’d like to know what that means — what’s been lost.”

ALTERNATIVE: BIOLOGICAL CONDITION GRADIENT MODEL

*The **Biological Condition Gradient**: as stress increases, community composition changes in predictable ways*

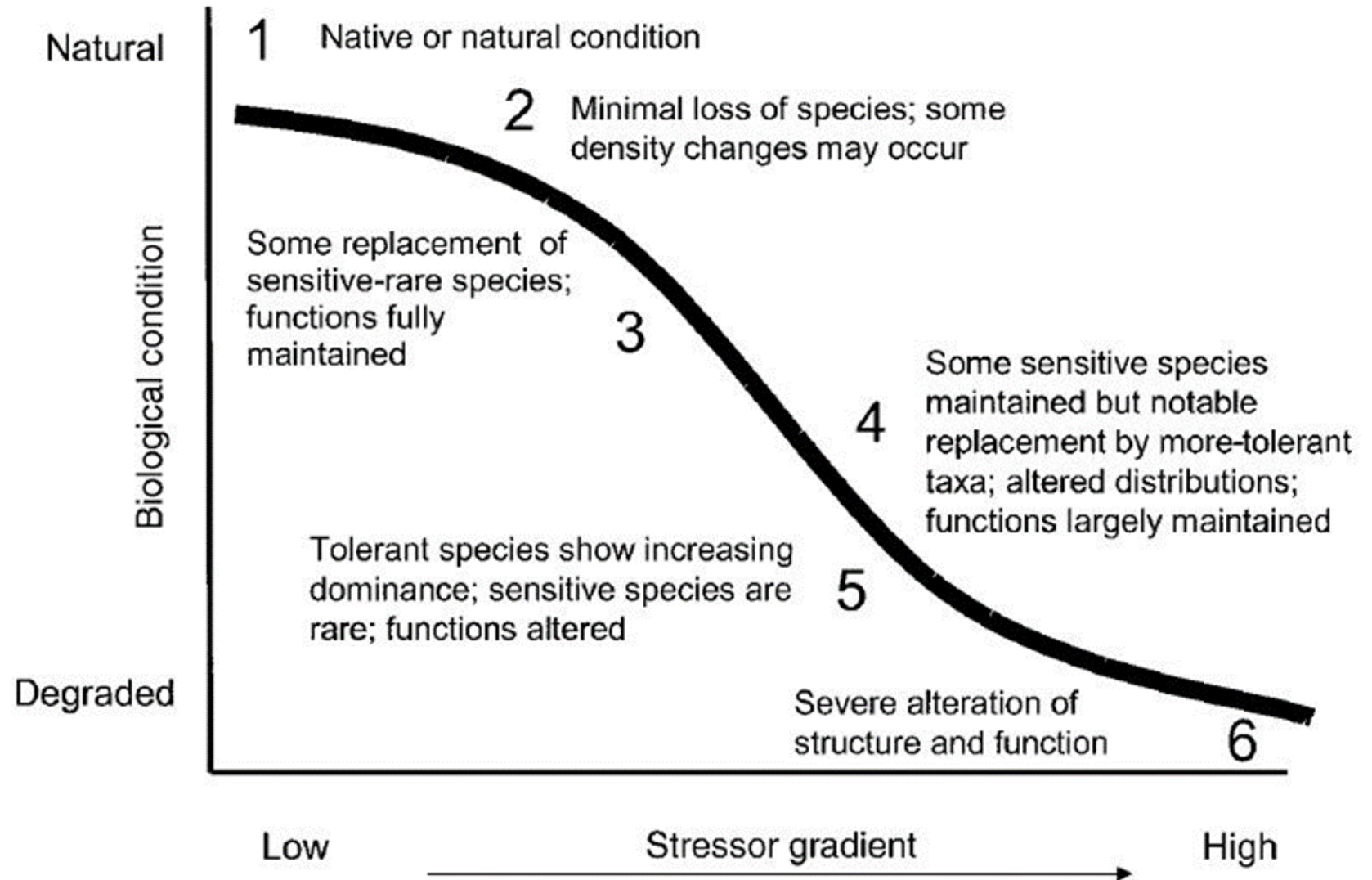

MOTIVATION FOR BCG

- California has powerful biological indices for assessment BUT numeric values do not communicate the ecological change associated with an index
 - ...THEREFORE we want to use the BCG calibration effort to do that.
- BCG models convey, in ecological terms, the breadth and depth of ecological change in a way numbers often cannot.

WHAT IT INVOLVES: EXPERT INTERPRETATION OF TAXONOMIC INFORMATION TO INFER CONDITION

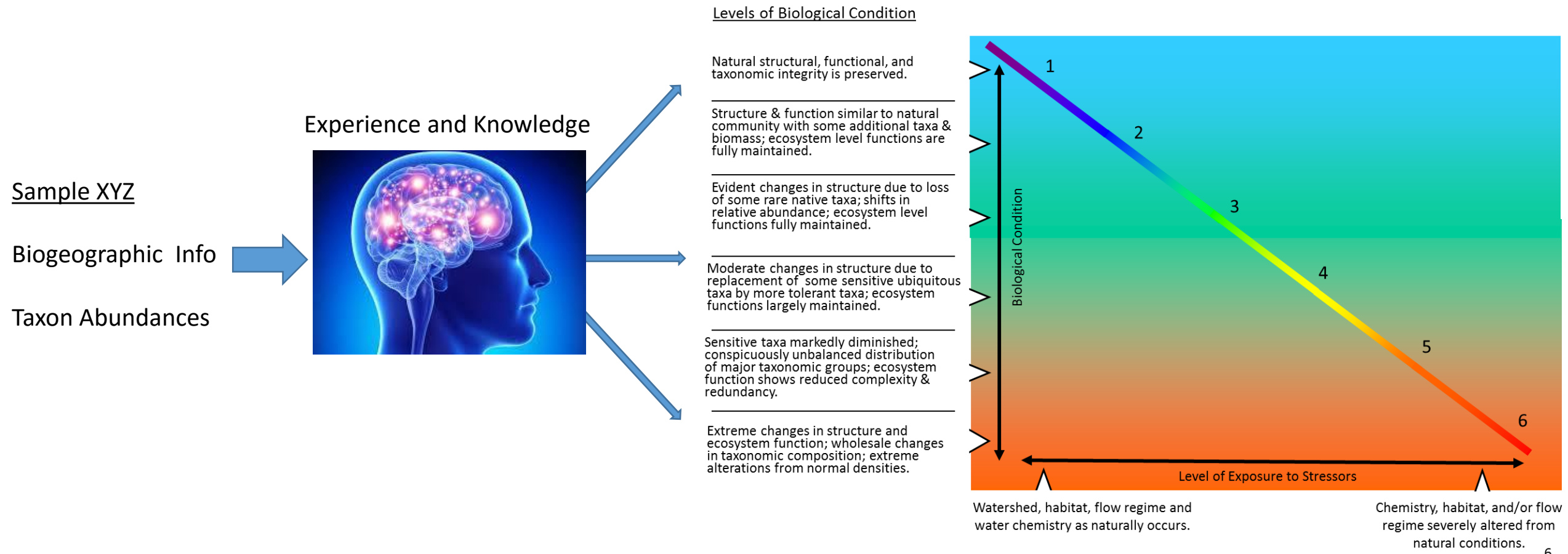

QUICK VIEW OF BCG DEVELOPMENT PROCESS

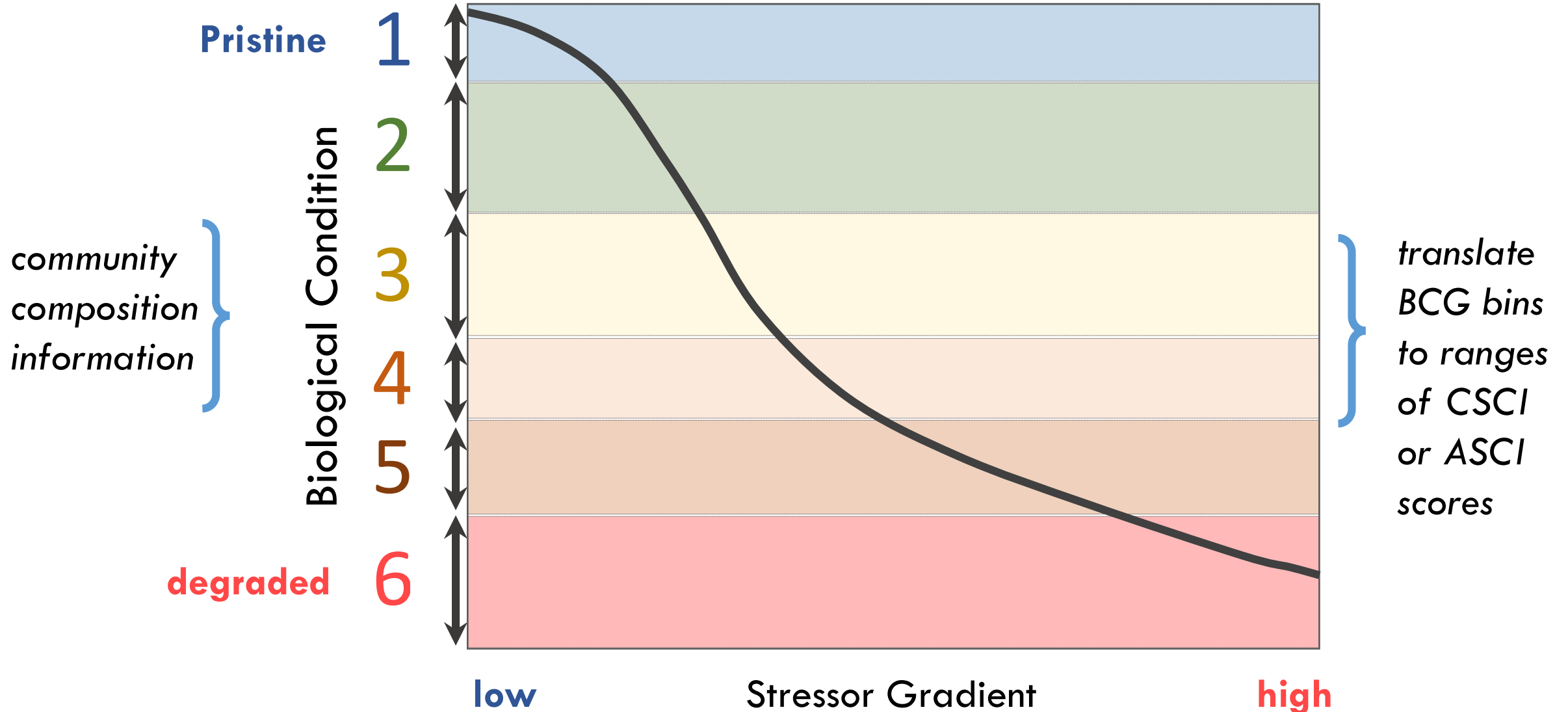

THEN...USE STATISTICAL MODELS TO MAP BCG BINNED INDICES TO DEFAULT STRESSOR TARGETS (NUTRIENTS IN EUTROPHICATION SYNTHESIS)

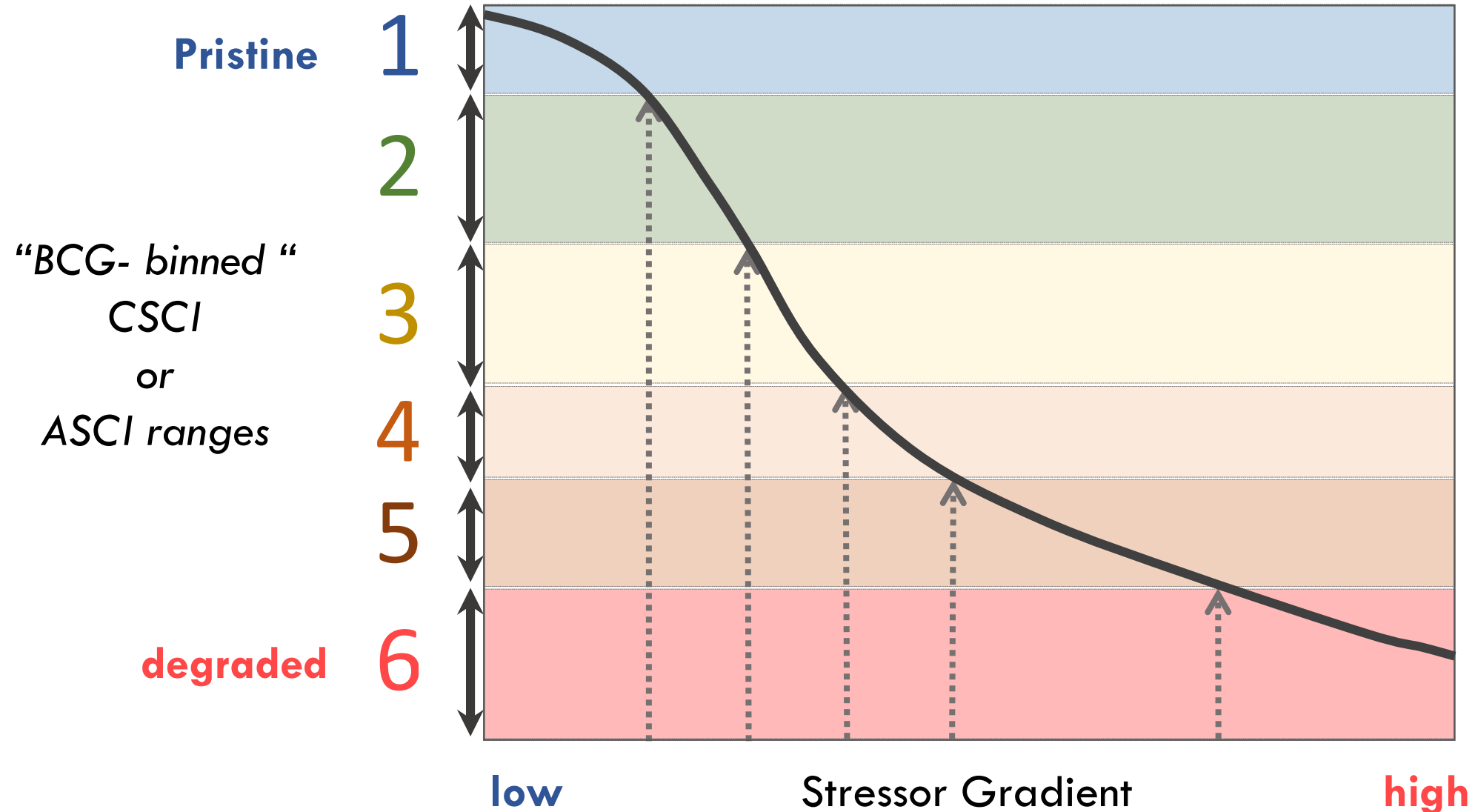

MEET THE EXPERTS THAT WE'VE RECRUITED

Benthic Invertebrates

Larry Brown

James Carter

David Herbst

Jeanette Howard

Bill Isham

Jason May

Patina Mendez

John Olson

Alison O'Dowd

Andy Rehn

Algae

Don Charles

Rex Lowe

Yangdong Pan

Robert Sheath

Sarah Spaulding

Rosalina Stancheva

HOW DOES THIS WORK AGAIN?

STEP 1 (NOVEMBER 10, 2016 WEBINAR)

BMI and algal taxa have specific responses to stress

- Assign attributes of bug and algal taxa to BCG bins
- Consensus on general taxonomic attributes is important

Examples of attributes

- Rare/endemic
- Highly Sensitive
- Intermediate Sensitive
- Intermediate (cosmopolitan)
- Tolerant
- Non-native

STEP 2 (WORKSHOP 1; DECEMBER 1-2, 2016)

- Experts assign sites to BCG levels
- Separate effort for inverts and algae
- Describe rationale for assignment

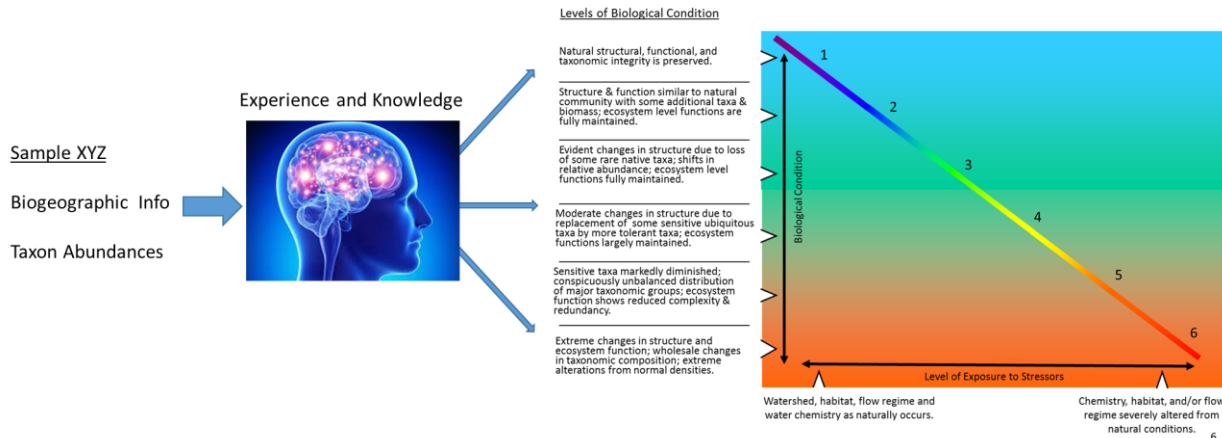

Hypothetical Invertebrate Worksheet

Mystery Creek
 O = 11
 E = 16.5
 Metrics = observed score (predicted)
 Taxonomic Richness = 11 (17)
 Shredder Taxa Richness = 4 (7)
 Percent Clinger Taxa = 34% (45%)
 Percent Coleoptera Taxa = 18% (25%)
 Percent EPT Taxa = 25% (40%)
 Percent Intolerant Individuals = 35% (55%)

Elevation = 300m
 Annual Precipitation = 14 cm
 Geology = Y
 Ecoregion = X
 Stream order = 2
 Wetted width = 3m
 Etc
 Etc

Taxon Abundances:

1 = 12 10 = 20
 2 = 13 11 = 14
 3 = 7 12 = 3
 4 = 34 13 = 10
 5 = 40 14 = 40
 6 = 10 15 = 34
 7 = 3 16 = 7
 8 = 14 17 = 13
 9 = 20 18 = 12

Information in BCG attribute form too (e.g.):

ExerciseID	Samp0031	Assigned Tier	Reasoning	
Collection Date	7/23/2007			
Collection Method	BMI_RWB			
TAXA SUMMARY				
BCG Attribute	Number of Taxa	Count	Pct Taxa	Pct Individuals
1	0	0	0%	0%
2	1	7	6%	3%
3	5	57	28%	19%
4	6	121	33%	40%
5	6	115	33%	38%
6	0	0	0%	0%
X	0	0	0%	0%
Total	18	300	100%	100%

STEP 3 (WORKSHOP 2): JANUARY 10-11, 2017

Experts Work Towards Consensus

- Review samples with high variability in assigned BCG levels
- Re-vote, working towards agreement of the core level
- This is done separately for invertebrates and algae

	BCG Level					
	CSCI	ASCI	Expert 1	Expert 2	Expert 3	Expert 4
Site X	0.3		5	4	5	5
Site Y	0.8	0.7	2	3	3	2
Site Z	0.2	0.3	5	6	6	6
Site A		0.5	4	4	3	3
	•	•	•	•	•	•

“This sample is a BCG level 3 because it has plenty of sensitive taxa and a good balance of functional groups.”

“It is a 2 because most of the CSCI metrics meet expectations”

“It is not a 2 because it is missing some taxa that should be in an undisturbed site”

KEY OUTPUT AT THE END OF WORKSHOPS

- Sites with CSCI scores
- Sites with ASCI scores
- Expert consensus BCG level assignment for those same sites
- Expert interpretation of why those assignments were made

Site X	CSCI	Expert 1	Expert 2	Expert 3	Expert 4	Consensus
First Vote		5	4	5	5	
Revote	0.3	5	5	5	5	5

“The sample is a BCG level 5 because it is lacking sensitive taxa (no attribute 2 and few 3s), is dominated by tolerant taxa (55% attribute 5s), and shows an imbalance of functional groups. It is not a level 6 because there is at least 1 attribute 3 and richness shows some diversity (>15 taxa). This agrees with a CSCI score of 0.30.”

USE OUTPUT TO DESCRIBE BCG BINNED RANGES OF CSCI AND ASCI

- What is the distribution of CSCI or ASCI scores by BCG category?
- How is the CSCI or ASCI translated into degrees of biological impact?

BCG Levels

1 Natural structural, functional, and taxonomic integrity is preserved.

2 Structure & function similar to natural community with some additional taxa & biomass; ecosystem level functions are fully maintained.

3 Evident changes in structure due to loss of some rare native taxa; shifts in relative abundance; ecosystem level functions fully maintained.

4 Moderate changes in structure due to replacement of some sensitive ubiquitous taxa by more tolerant taxa; ecosystem functions largely maintained.

5 Sensitive taxa markedly diminished; conspicuously unbalanced distribution of major taxonomic groups; ecosystem function shows reduced complexity & redundancy.

6 Extreme changes in structure and ecosystem function; wholesale changes in taxonomic composition; extreme alterations from normal densities.

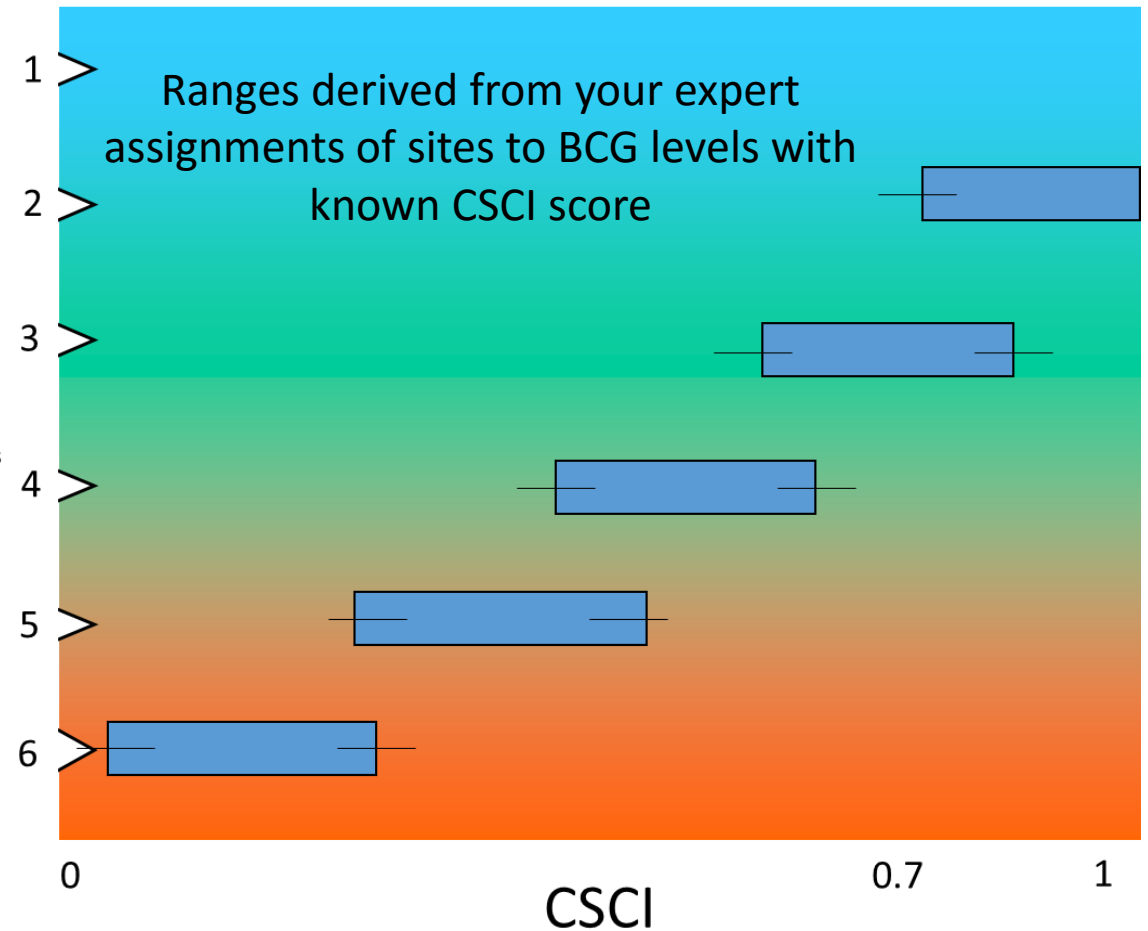

HOW BCG CAN BE USED: SUPPORT POLICY DECISIONS ON ASSESSMENT ENDPOINTS FOR CSCI AND ASCI

- A CSCI of 0.7 is where we see a threshold in stressor response.
- “That CSCI score is associated with a loss of many sensitive taxa and is just above where tolerant taxa may begin replacing these taxa. Functional alteration often begins below this as well.”

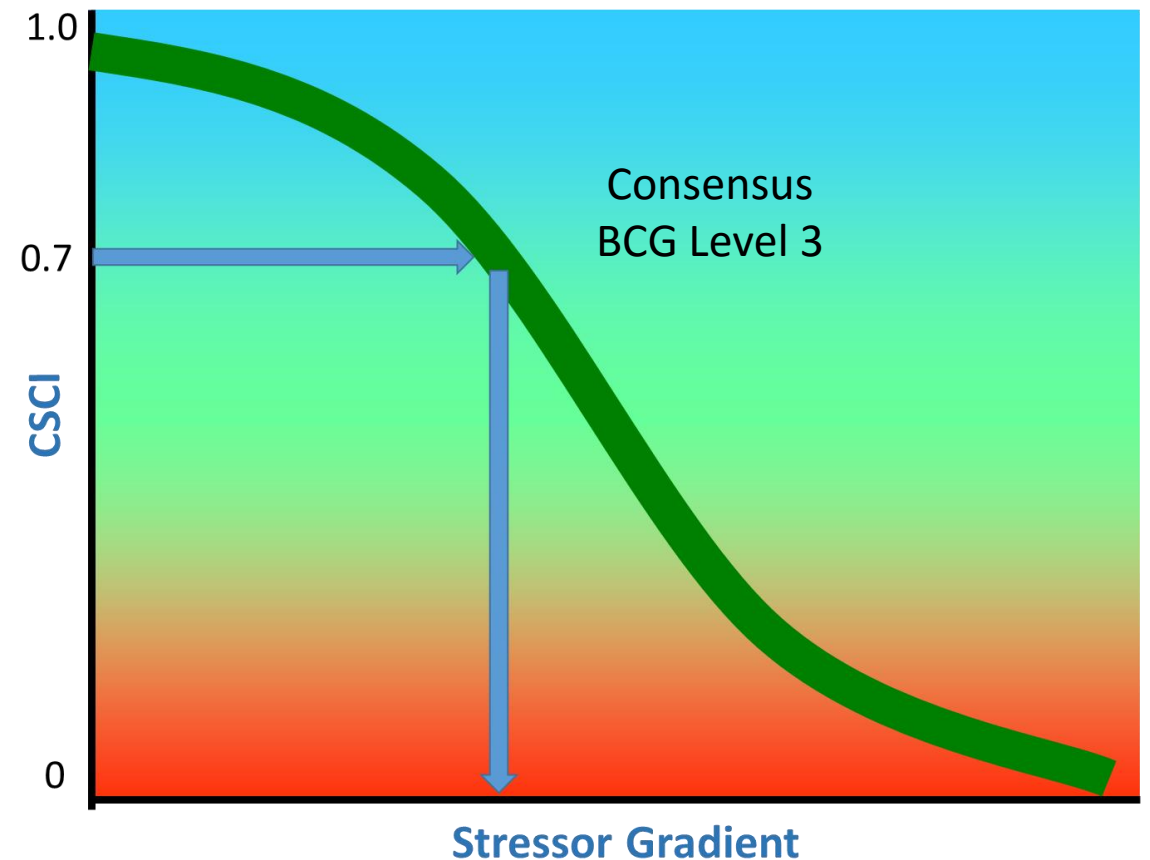

APPLICATIONS FOR “CHANNELS IN DEVELOPED LANDSCAPES”

- What are the best conditions of modified streams?
- What ecological characteristics can the best of those maintain?
- How does that inform goals for modified channels?

BCG Levels

1 Natural structural, functional, and taxonomic integrity is preserved.

2 Structure & function similar to natural community with some additional taxa & biomass; ecosystem level functions are fully maintained.

3 Evident changes in structure due to loss of some rare native taxa; shifts in relative abundance; ecosystem level functions fully maintained.

4 Moderate changes in structure due to replacement of some sensitive ubiquitous taxa by more tolerant taxa; ecosystem functions largely maintained.

5 Sensitive taxa markedly diminished; conspicuously unbalanced distribution of major taxonomic groups; ecosystem function shows reduced complexity & redundancy.

6 Extreme changes in structure and ecosystem function; wholesale changes in taxonomic composition; extreme alterations from normal densities.

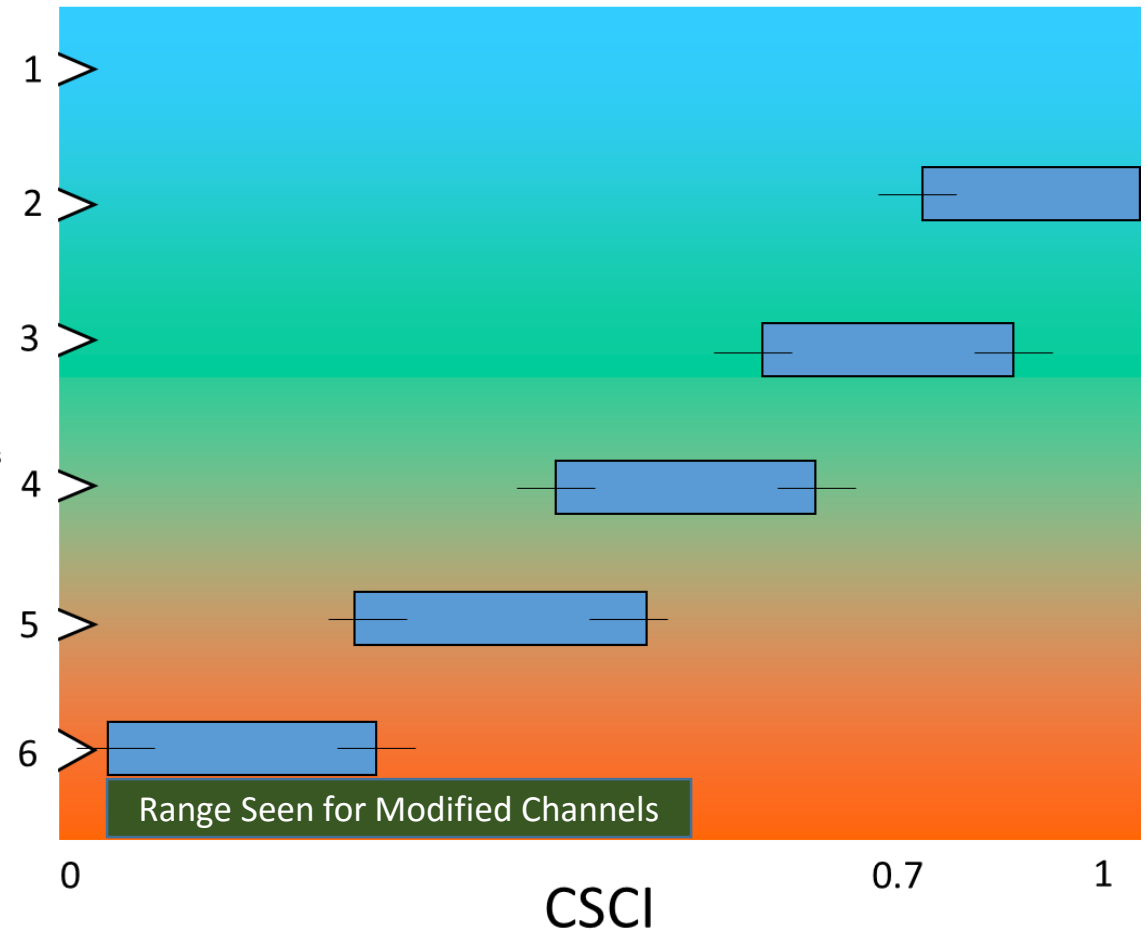

PRODUCTS OF BCG EXPERT CALIBRATION

- Report/manuscript that maps CSCI and ASCI indices to bins of ecological condition, from very high to very low
 - Oral findings – Summer 2017
 - Report anticipated fall 2017

ELEMENTS OF THE SCIENCE PLAN

1. Conduct and synthesize science supporting development of numeric guidance for wadeable streams
 - 1.1 Develop biological indices indicative of aquatic life use support
 - 1.2 Determine the numeric range of biological indices that correspond to attainment of beneficial uses
 - 1.3. Determine the range of stream nutrients and intermediate eutrophication response indicators that correspond to attainment of beneficial uses**
2. Implementation plan technical support

EUTROPHICATION SYNTHESIS KEY COMPONENTS

- Conceptual model
- Review of candidate indicators and causal assessment metrics
 - Synthesis of science supporting decisions on assessment endpoints
- Synthesis of science supporting decisions on nutrient targets
 - Statistical models that can be used to link assessment endpoints to nutrient concentrations, in order to set “default” targets

Stream Eutrophication Conceptual Model

↑ N, P
nutrient
enrichment



excessive growth of
primary producers
(algae and/or
higher plants)

shifts in algal community composition



also **directly** impact food webs

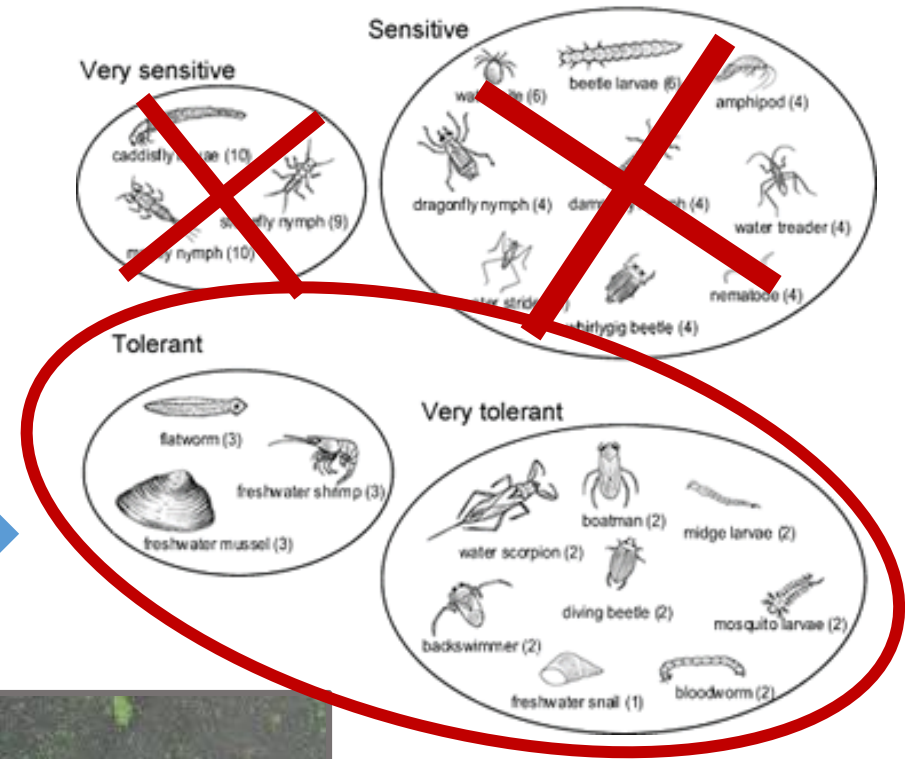

from multiple
standpoints,
eutrophication
alters aquatic life

Eutrophication Response Pathways: Relationships with **Multiple** Beneficial Use Types

Beneficial Use	Altered Aquatic Life Diversity	Altered Food Web	Unaesthetic Blooms	Water Quality: Reduced DO	Water Quality: Algal Toxins <i>et al.</i> Metabolites	Water Quality: Increased Turbidity
COLD	X	X		X	X	X
WARM	X	X		X	X	
SPWN	X	X		X	X	
MIGR	X	X		X	X	
RARE	X	X		X	X	
MUN					X	X
REC-1			X	X	X	X
REC-2			X			X

adapted from Tetra Tech (2006)

CANDIDATE EUTROPHICATION RESPONSE INDICATORS, BY PATHWAY

Routinely Monitored

- *Altered Aquatic Diversity, Food Webs*
 - **CSCI, ASCI**
- *Organic Matter accumulation*
 - ✓ benthic algal chlorophyll *a*,
 - ✓ benthic ash-free dry mass (AFDM)
 - ✓ algal & macrophyte percent cover

Not Routinely Sampled

- *Altered Water Quality*
 - ✓ dissolved oxygen/pH
 - algal toxins
 - turbidity
 - trihalomethanes
- ✓ DENOTES CAUSAL FOR BIOSTIMULATORY CONDITIONS=
CANDIDATE INTERMEDIATE
RESPONSE INDICATORS

BENTHIC INVERTEBRATE AND ALGAL ATTRIBUTES CAN PROVIDE “EUTROPHICATION” METRICS FOR RAPID CAUSAL ASSESSMENT

“Functional Traits” Indicative Pathways of Impairment, for Example..

- Organic matter enrichment
- DO and pH tolerance
- Toxicity or tolerance for nutrient species (Nitrate, phosphate)

Long-term goals is to build this into a “dashboard” of output from bioassessment results (rapid causal assessment)

But for eutrophication synthesis, this will be a curated list

VIEW OF INDICATORS AND ASSESSMENT ENDPOINTS FOR EUTROPHICATION

Assessment
Endpoints to Protect
Biointegrity From
Biostimulatory Conditions
for:

CSCI and ASCI

Benthic Chl-a/AFDM
DO and pH

Causal Assessment
Metrics

Preliminary Diagnosis Through Causal Assessment, e.g.:

- If organic matter indicators do not meet endpoints, but CSCI/ASCI do, then site is not impaired
- If CSCI/ASCI AND organic matter/DO indicators do not meet assessment endpoints, then site is causal for biostimulatory
- If CSCI/ASCI do not meet endpoints but organic matter or DO indicators do, then ID other stressors
 - Causal assessment metrics point to relevant pathway (toxics, etc.)

EUTROPHICATION SYNTHESIS KEY COMPONENTS

- Conceptual model
- Review of candidate indicators and causal assessment metrics
 - Synthesis of science supporting decisions on assessment endpoints
- Synthesis of science supporting decisions on nutrient targets
 - Statistical models that can be used to link assessment endpoints to nutrient concentrations, in order to set “default” targets

Beneficial Use Protection

Aquatic Life Indicators

Benthic Macro-invertebrate and Benthic Algae Community

Approaches to Link Nutrients to Beneficial Uses

Biological Condition Gradient Model

Statistical Detection of Thresholds (EPA-ORD Final Report)

Percent of Reference Distributions

Nutrient Targets

Nitrogen (TN, NO_x, NH₄)
Phosphorus (PO₄, TP)

From August 26, 2015 NNE Webinar

AUGUST 2015 WEBINAR: APPROACHES TO LINK NUTRIENTS TO RESPONSE INDICATORS

Beneficial Use Protection

Aquatic Life Indicators



Nutrient Targets

Benthic Macro-invertebrate Community



Benthic Algae Community

Response Indicator:
Algal and organic matter abundance

Nitrogen (TN, NO_x, NH₄)
Phosphorus (PO₄, TP)

AUGUST 2015 WEBINAR: MODEL LINKAGE OF NUTRIENTS TO RESPONSE INDICATORS

Beneficial Use Protection

Aquatic Life Indicators

Benthic Macro-invertebrate Community

Benthic Algae Community

Response Indicator Endpoints

Nutrient Targets

Indirect Linkage

Invertebrate or Algal Community IBI

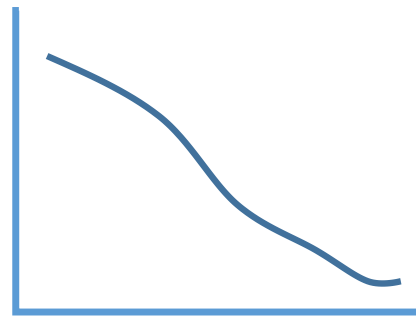

Algal Abundance

Algal Abundance

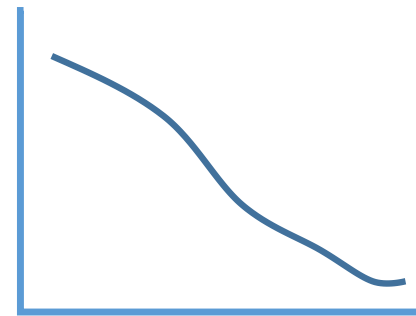

Nutrients

Nitrogen (TN, NO_x, NH₄)

Phosphorus (PO₄, TP)

AUGUST 2015 WEBINAR: MODELING RELATIONSHIP BETWEEN POTENTIAL RESPONSE INDICATORS AND NUTRIENTS

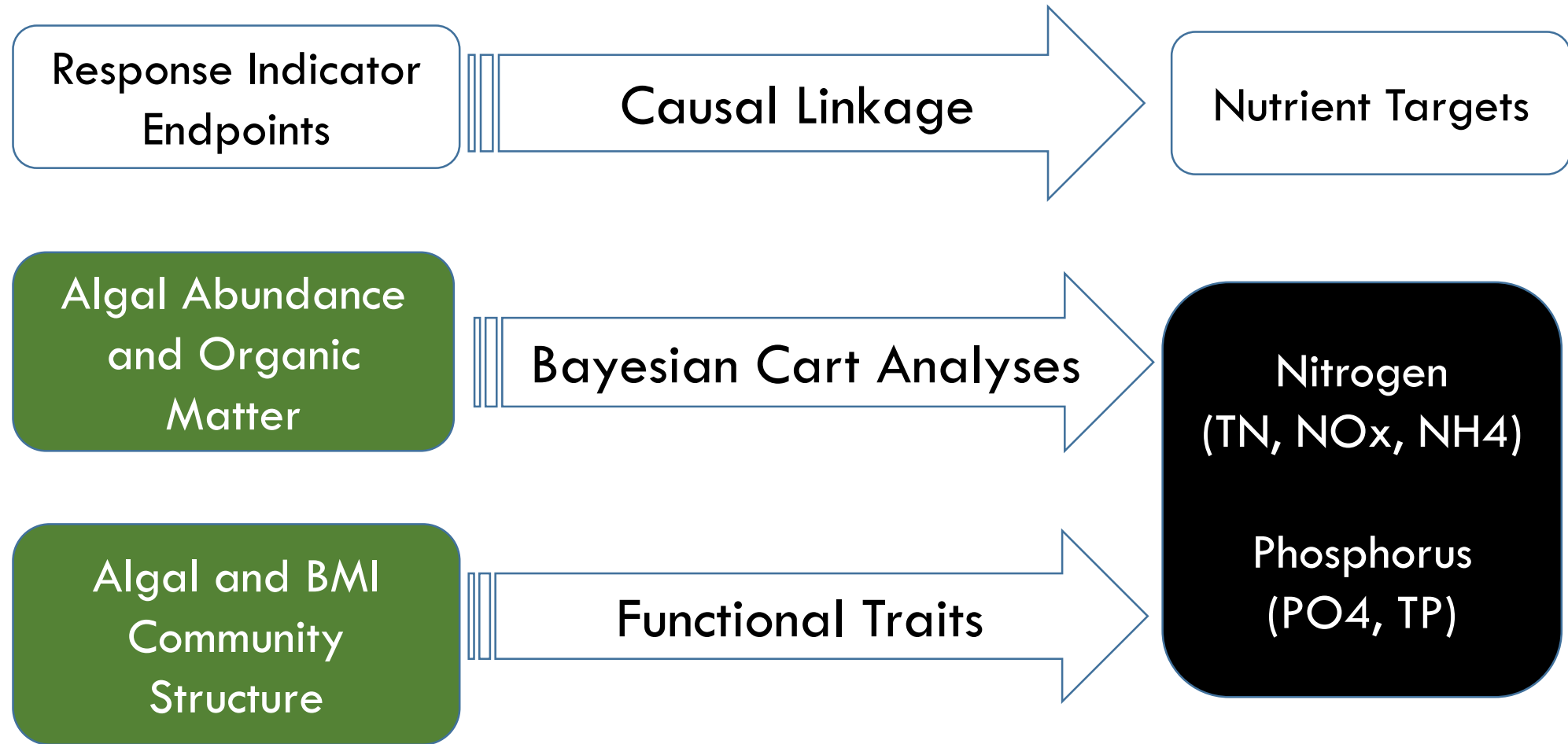

From August 26, 2015 NNE Webinar

WHAT DID WE LEARN FROM STATEWIDE B-CART MODELS RELATING NUTRIENT AND SITE-SPECIFIC FACTORS TO ORGANIC MATTER

- Models including anthropogenic disturbance variables performed better than those just using natural gradients
- Models relying solely on site-specific factors “mechanistic” for eutrophication performed mediocre
 - Not strongly defensible method to establish “site-specific nutrient targets

Take Home Message:

- Creation of models to establish “site-specific nutrient targets” is appropriate at watershed or waterbody-specific, not statewide scale
- Move away from mechanistic modeling at statewide scale

IF NOT MECHANISTIC MODELS, THEN WHAT?

- Recognize that biological condition can degrade along gradient of increasing nutrients, other biostimulatory conditions, and organic matter enrichment (OM)
- Use statistical models to define ranges of nutrient and OM that have probability of being protective, in “default” mode

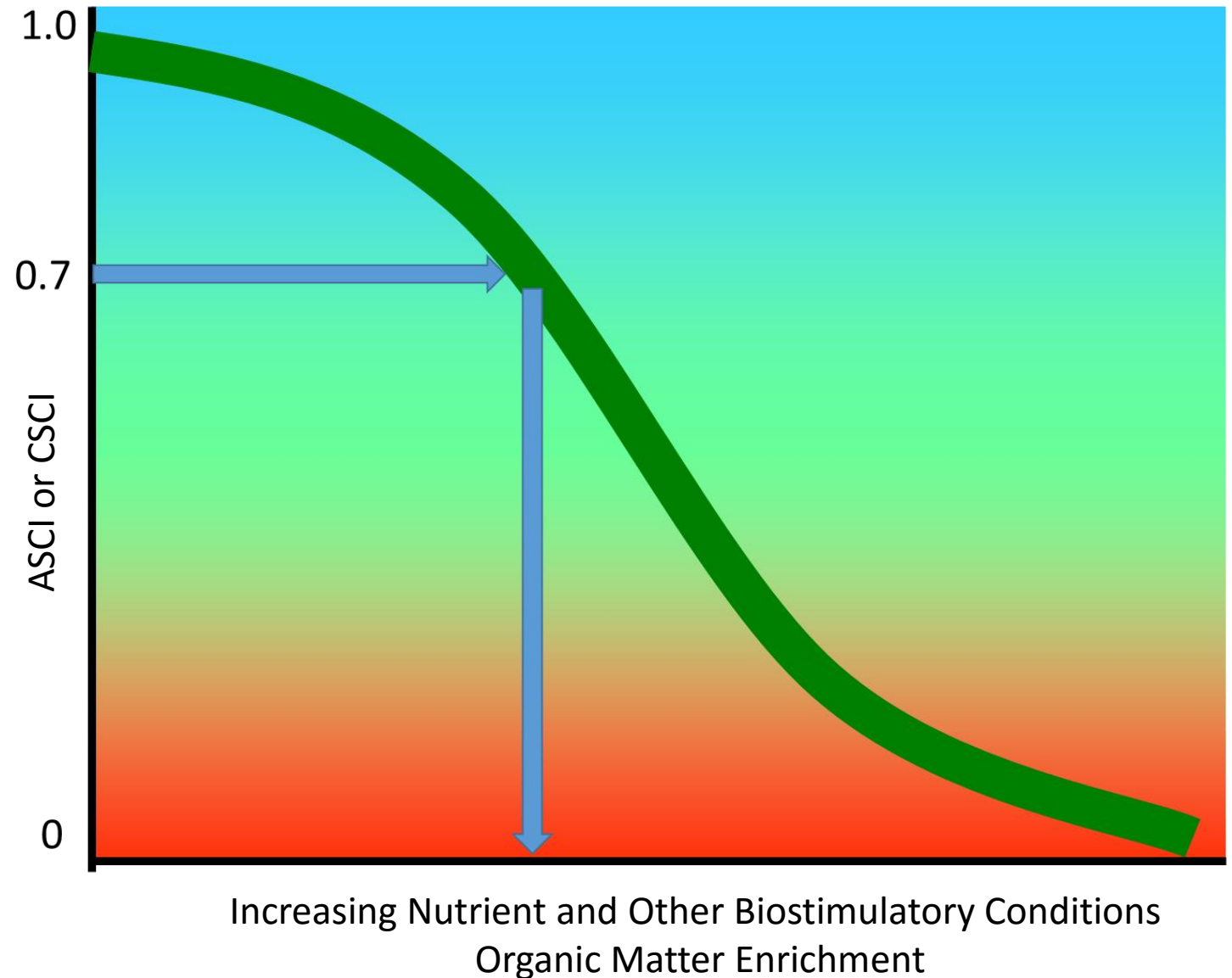

ACCOUNT FOR BIOSTIMULATORY CONDITIONS AT WATERSHED SCALE

Can Establish Assessment Endpoints to Protect Biointegrity From Biostimulatory Conditions:
CSCI and ASCI

Benthic Chl-a/AFDM
DO and pH

Causal Assessment Metrics

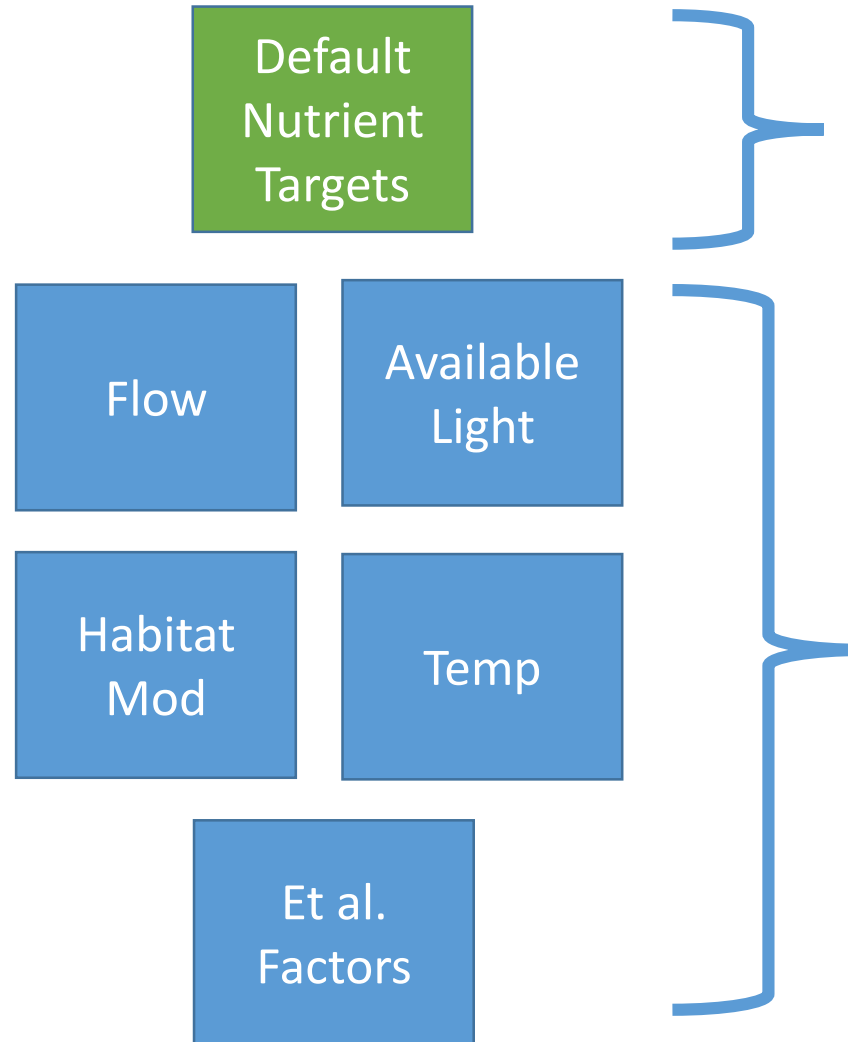

Set default nutrient targets.....

But use watershed approach to account for other factors to reach biological assessment endpoints.....

USE STATISTICAL MODELS TO MAP BCG BINNED INDICES TO NUTRIENTS AND INTERMEDIATE RESPONSE INDICATORS

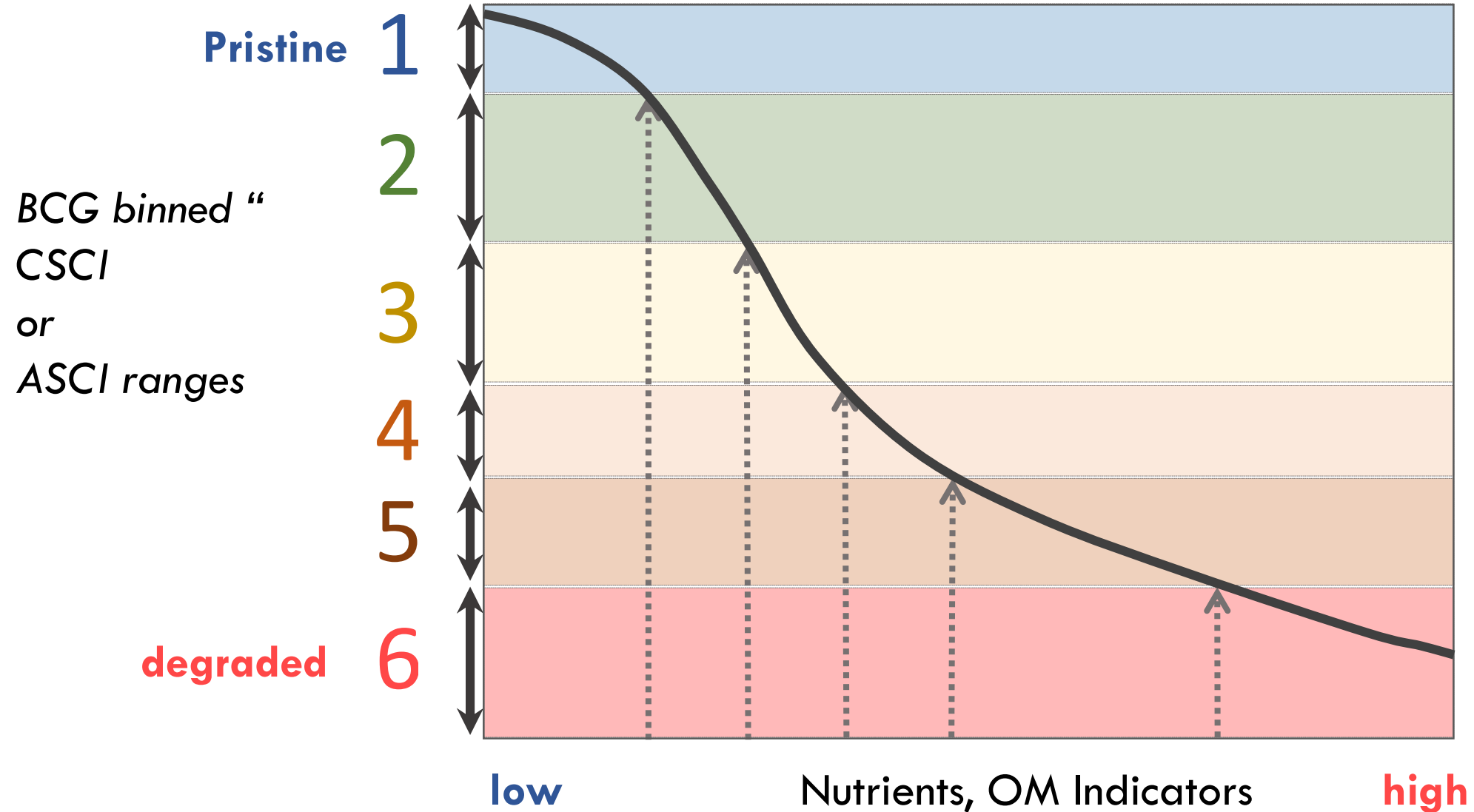

STATISTICAL MODEL APPROACHES TO LINK CSCI AND ASCI TO NUTRIENTS AND ORGANIC MATTER

Recommend regression approaches, with two possible types, depending on policy question

- Nonlinear (e.g. Quantile) regression

“What are the ranges and uncertainty in TN concentration associated with a BCG-binned ranges of ASCI?”

- Logistic regression

“What is the benthic chl-a concentration and associated error that has a probability of 0.5 of CSCI falling below X?”

For either of these approaches, can use classification and regression trees to reduce variability from natural gradients

SYNTHESIZING INFORMATION TO SUPPORT DECISIONS ON ASSESSMENT DEFAULT NUTRIENT AND ORGANIC MATTER THRESHOLDS

Compare “BCG-binned” ranges of TN, TP and organic matter indicators to ranges from two other approaches:

EPA ORD report “statistically-derived” thresholds

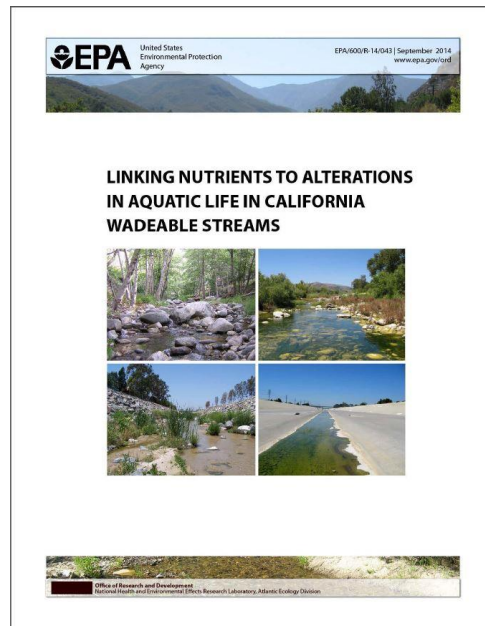

Percentile of Reference

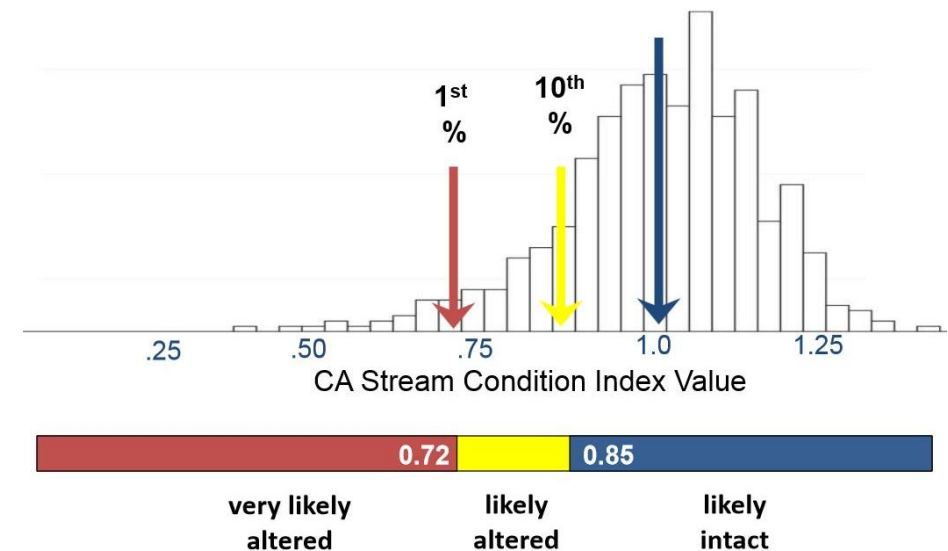

PRODUCTS OF EUTROPHICATION SYNTHESIS

- Report/ that provides:
 - Conceptual model of eutrophication in wadeable streams and linkages to beneficial use impacts
 - General review of candidate eutrophication indicators, including BMI and algal community metrics that are causal for eutrophication pathways
 - Statistical models linking CSCI and ASCI to nutrient concentrations and intermediate eutrophication response, in BCG-binned ranges
 - Recommendations for their use
- Draft report expected winter 2017, but interactions with science panel would already occur this spring 2017.

HOW IS THE BIOSTIMULATORY COMPONENT OF THE SCIENCE PLAN REALLY DIFFERENT FROM PREVIOUS VERSION?

- Conceptual model
 - Same as previous NNE workplan
- Review of candidate indicators to support decisions on assessment endpoints
 - Same foundation, but increased emphasis on causal assessment metrics (but not for the purposes of establishing assessment endpoints)
- Synthesis of science supporting decisions on nutrient targets
 - Same concept that statistical models that can be used to link assessment endpoints to nutrient concentrations, in order to set “default” targets
 - Move away from mechanistic “site specific targets” as a goal for statewide statistical models

RECAP-TIMING OF PRODUCTS: ELEMENT 1

July 2017

- Oral presentation on findings (ASCI, BCG)

September 2017

- Draft reports (ASCI, BCG)
- Oral findings (eutrophication synthesis with statistical models linking to nutrients/OM)

November 2017

- Draft report (eutrotrophication synthesis with statistical models linking to nutrients/OM)

January 2018

- Revised reports (ASCI, BCG, eutrophication synthesis)

ELEMENTS OF THE SCIENCE PLAN

1. Conduct and synthesize science supporting development of numeric guidance for wadeable streams
 - 1.1 Develop biological indices indicative of aquatic life use support
 - 1.2 Determine the numeric range of biological indices that correspond to attainment of beneficial uses
 - 1.3. Determine the range of stream nutrients and intermediate eutrophication response indicators that correspond to attainment of beneficial uses
2. **Implementation plan technical support**

IMPLEMENTATION PLAN

- Number of technical elements funded to support biointegrity and biostimulatory policy implementation
 - We want to recognize in Science Panel that this work has been completed or is underway
 - Other elements have yet to be identified and funded, pending more specific policy options under consideration
- Opportunities for stakeholders to identify needed science and co-fund/contribute

EXAMPLE OF IMPLEMENTATION TECHNICAL ELEMENTS

- Completed
 - Regional study biological conditions in engineered channels
 - Pilot study on spatial representativeness
- Funded and in progress
 - Channels in Developed Landscapes
 - Pilot demonstrations of “watershed approach”, Santa Margarita River watershed
- Future
 - Streamlined causal assessment
 - [Identify these needs on an ongoing basis, with your input]

QUESTIONS?

COMMENTS?

REGIONAL STUDY ON ENGINEERED CHANNELS

- Funded by SMC for SoCal data
- High scores in engineered channels rare for CSCI, but common for algal indices
- Indices (especially the diatom index) have some ability respond to water/habitat quality gradients, even within concrete channels.

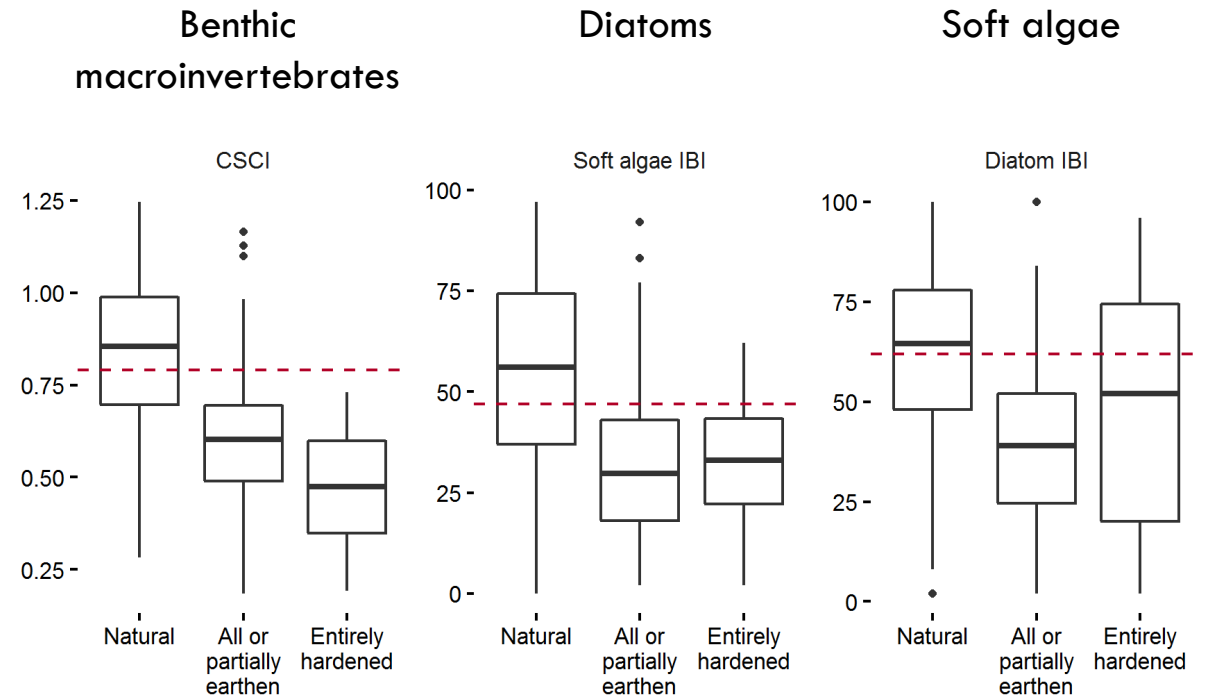

PILOT STUDY ON SPATIAL REPRESENTATIVENESS

- Spatial models allow extrapolation of scores from sampled sites to unsampled reaches
- Spatially explicit maps show confidence in estimates
- Maps can identify regions where additional sampling improves confidence
- Models built at the watershed scale. Next: Regional/statewide models, plus incorporation of land use in predictions.



CHANNELS IN DEVELOPED LANDSCAPES

- Define “developed” landscapes as those that are unlikely to support high index scores
- Predict max scores likely to be attained in each watershed, based on landscape-scale modifications
- Apply to maps

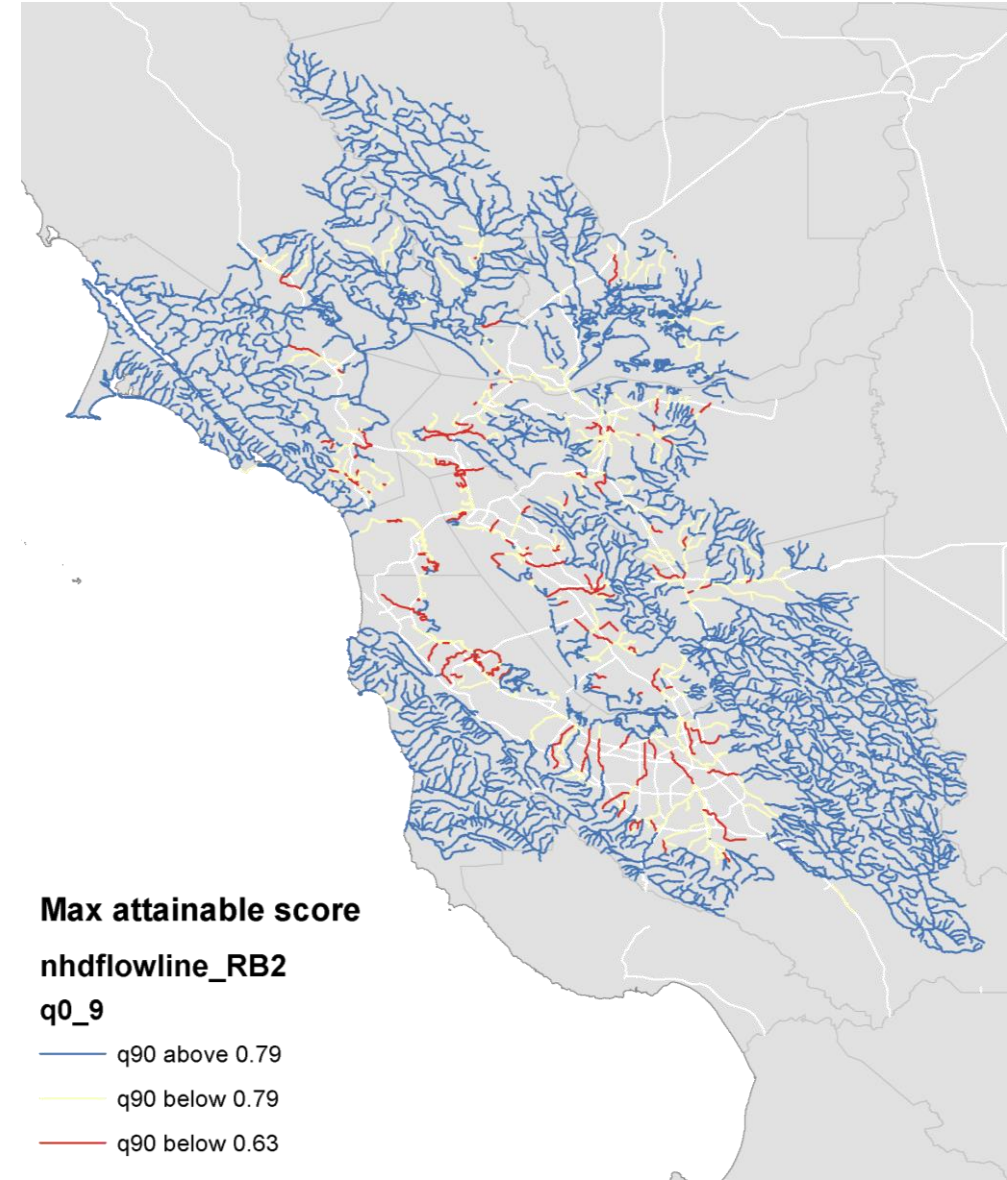
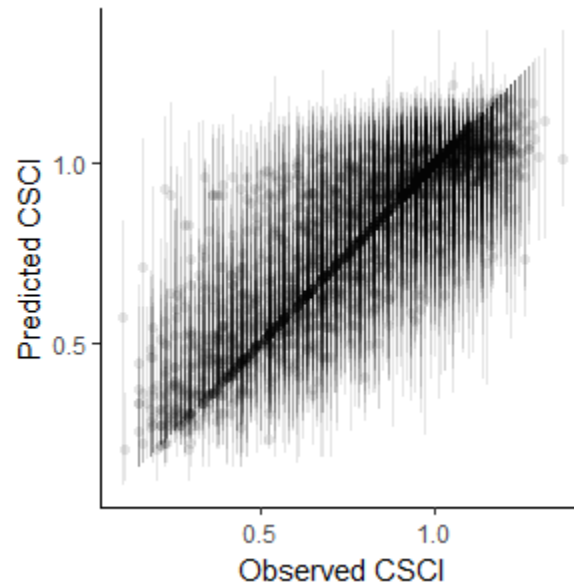

STREAMLINED CAUSAL ASSESSMENT

- Incorporate causal assessment into routine assessment
- Improve design of monitoring programs
- Automate selection of environmentally similar “comparator sites”
- Create tools for evaluating lines of evidence on candidate stressors

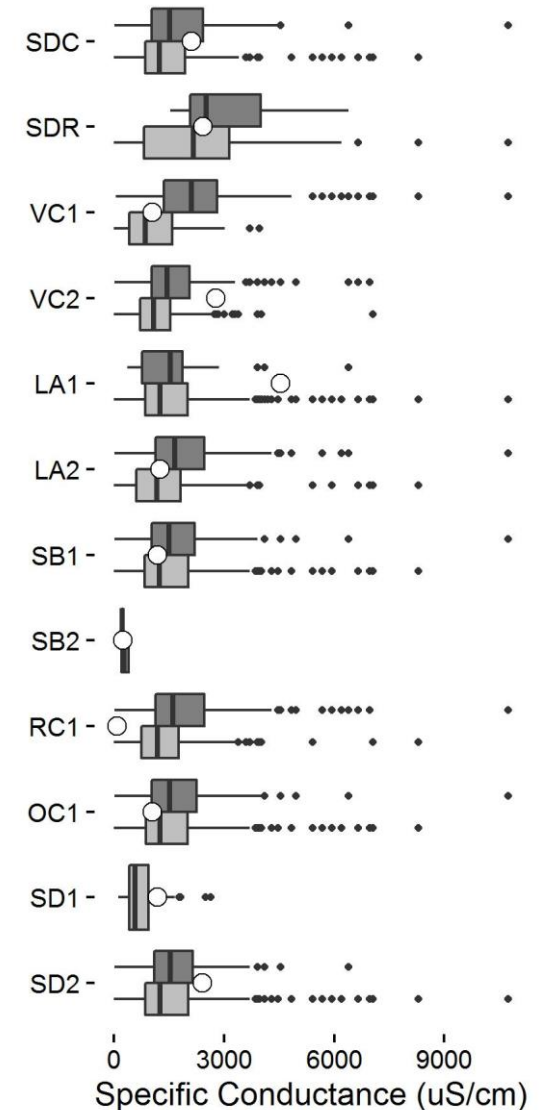

SCIENCE SUPPORTING POLICY: OVERVIEW OF PRESENTATION

- Conceptual approach and update on existing work elements
 - Martha Sutula
- Presentation of new technical elements- Susie Theroux
 - Algal Stream Condition Index (ASCI)

Algal Stream Condition Index (ASCI)



Susie Theroux
susannat@sccwrp.org

Context from this morning...

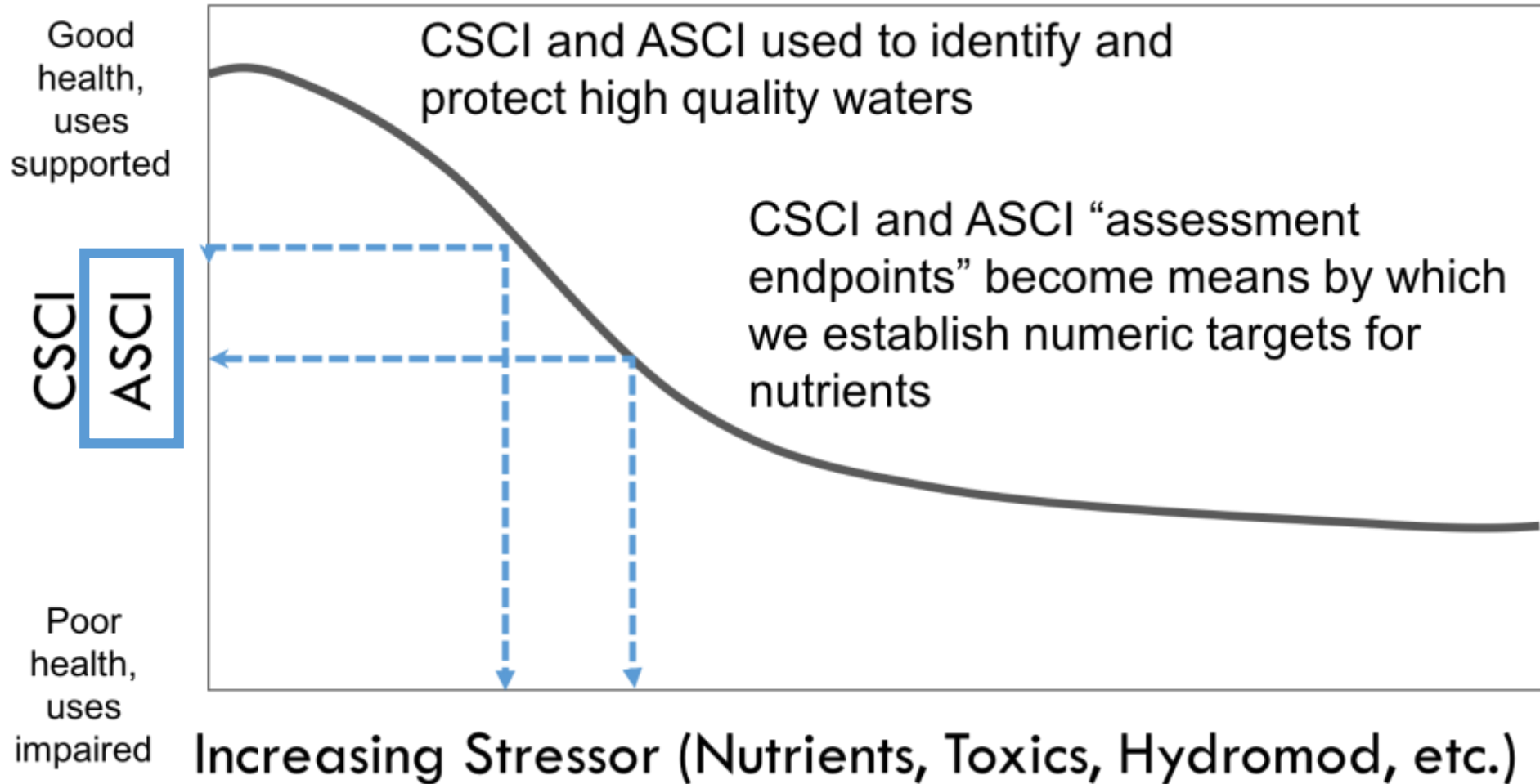

Roadmap: Introduction to ASCI



- Why algae?
- Previous work
- Approach and steps to develop ASCI
- Key products and timeline
- Implementation and future work

Why algae?

- Provide a direct link to nutrient concentrations and imbalances
- Sensitive to changes in water chemistry
- Short life span, rapid growth rate and rapid response to stress
- High dispersal rates and high species numbers



Why algae?

Soft-bodied algae (softs)

Diatoms

Cyanobacteria



Algal bioassessment in CA



SWAMP Bioassessment Procedures May 2016

STANDARD OPERATING PROCEDURES (SOP) FOR THE COLLECTION OF FIELD DATA FOR BIODASSESSMENTS OF CALIFORNIA WADEABLE STREAMS: BENTHIC MACROINVERTEBRATES, ALGAE, AND PHYSICAL HABITAT

Prepared by:

Peter R. Ode, Research Biologist, Water Pollution Control Laboratory, California Department of Fish and Wildlife

A. Elizabeth Fetscher, Senior Environmental Scientist, San Diego Regional Water Quality Control Board

Lilian B. Busse, Environmental Scientist, San Diego Regional Water Quality Control Board

SWAMP-SOP-SB-2016-0001

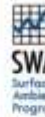

SWAMP Bioassessment Procedures 2015

Standard Operating Procedures for Laboratory Processing, Identification, and Enumeration of Stream Algae

September 2015

Rosalina Stancheva¹, Lilian Busse², Patrick Kociolek³ and Robert Sheath¹

¹California Primary Algae Laboratory
Department of Biological Sciences
California State University San Marcos
333 S. Twin Oaks Valley Road
San Marcos, CA 92966

²San Diego Regional Water Quality Control Board
State Water Resources Control Board
9174 Sky Park Court
San Diego, CA 92123

³Museum of Natural History and Department of Ecology
and Evolutionary Biology, University of Colorado
UCB 218, Boulder, CO 80309

SWAMP-SOP-2015-0003

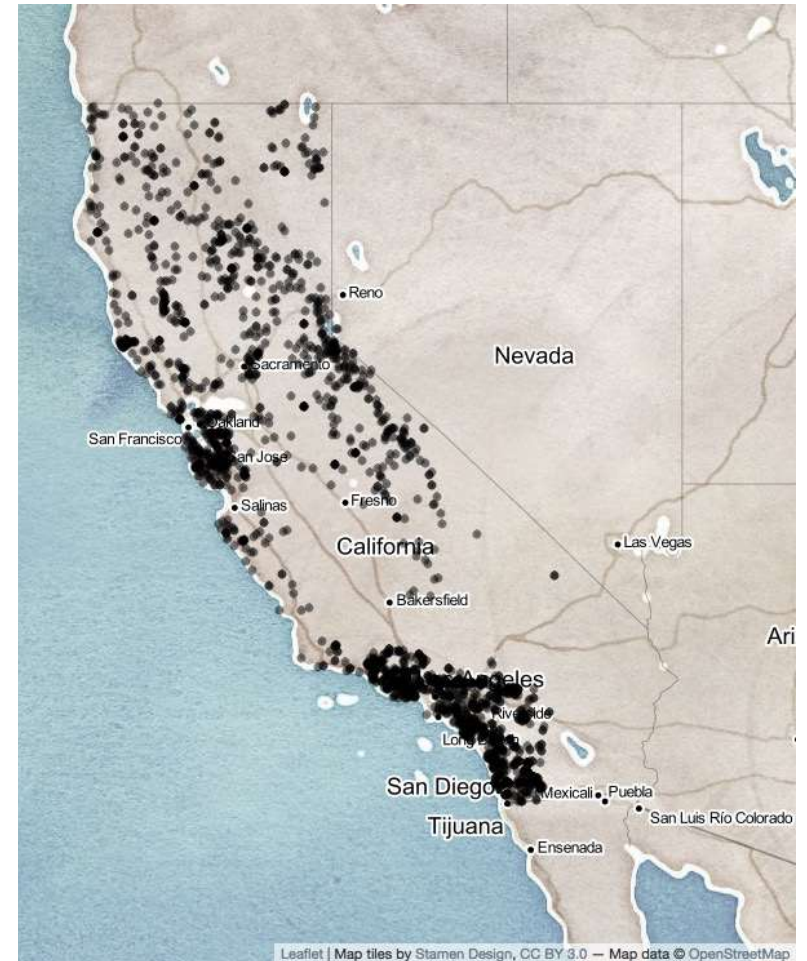

2008-2000

Algal Index of Biotic Integrity (IBI)

J Appl Phycol (2014) 26:433–450
DOI 10.1007/s10811-013-0088-2

Development and comparison of stream indices of biotic integrity using diatoms vs. non-diatom algae vs. a combination

A. Elizabeth Fetscher · Rosalina Stancheva ·
J. Patrick Kociolek · Robert G. Sheath · Eric D. Stein ·
Raphael D. Mazor · Peter R. Ode · Lilian B. Busse

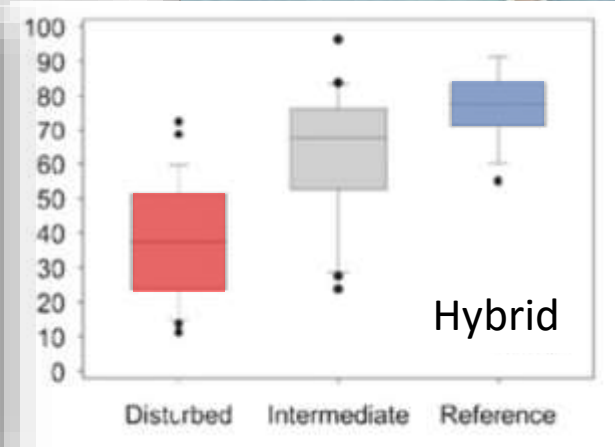
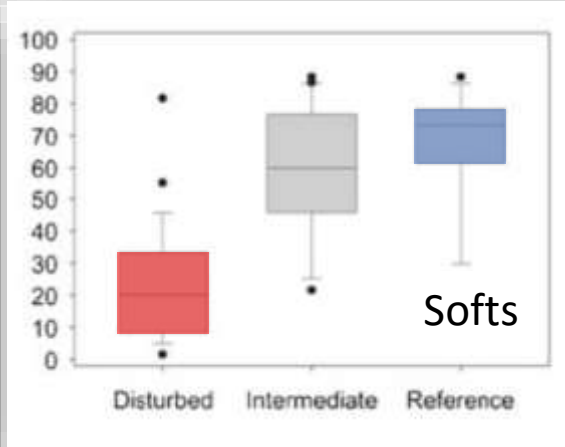
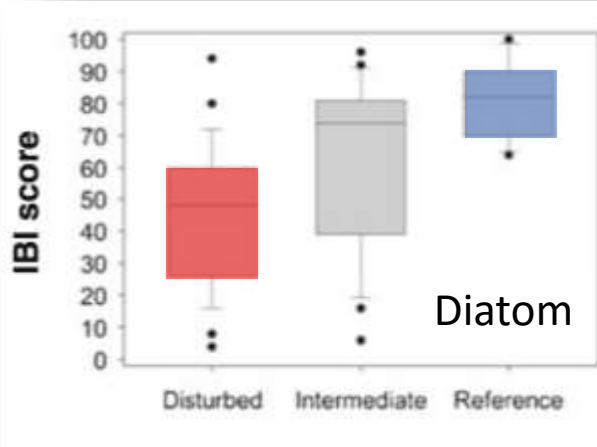
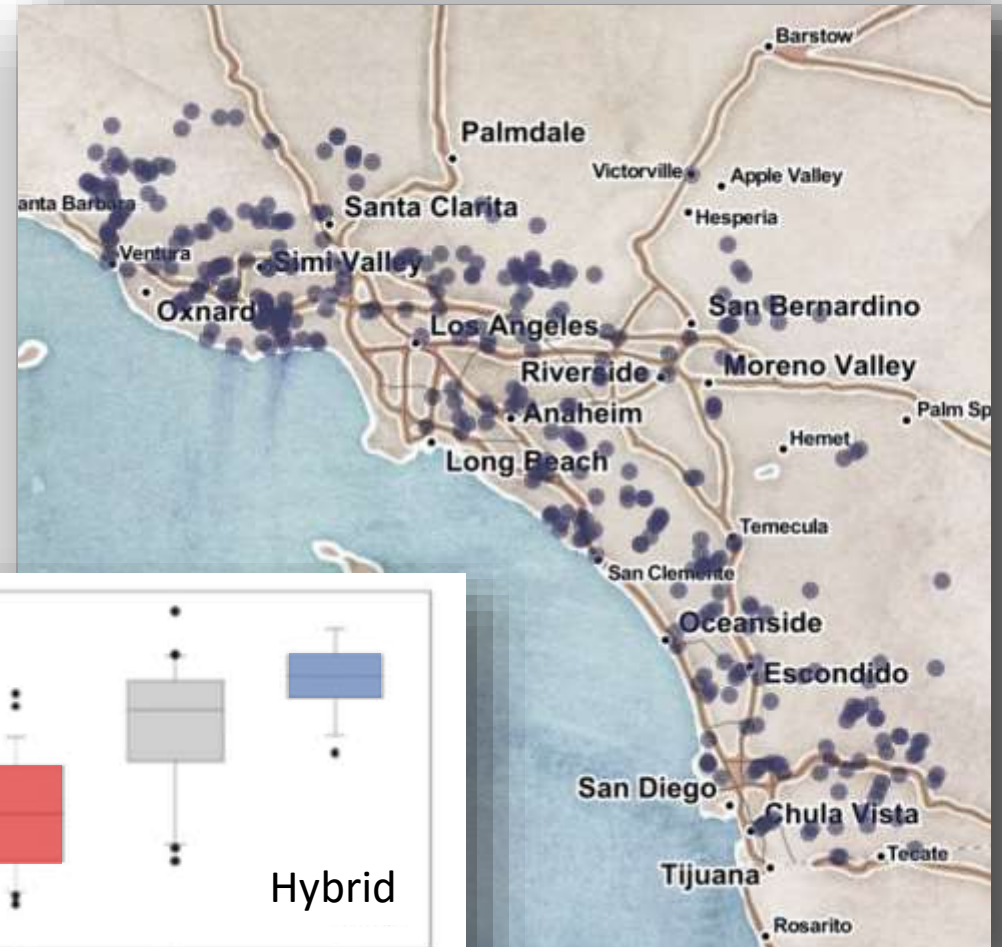

Statewide Algal Index (ASCI)

Develop a *predictive* algal index for California

- Large dataset spans California ecoregions
- Consistent tool to use across state
- Landscape setting informs site-specific reference expectations

Geology

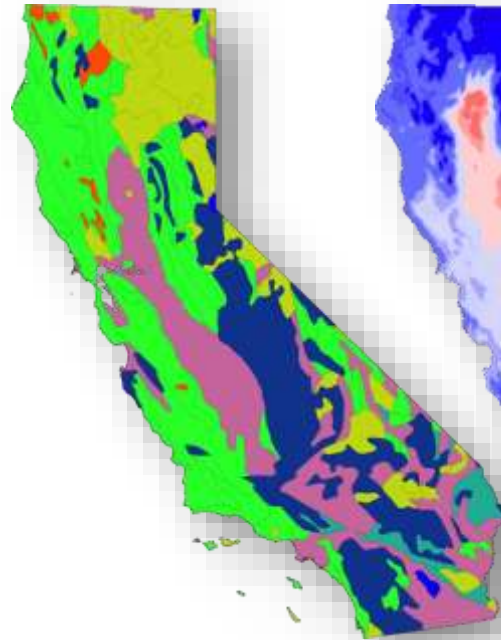

Temperature

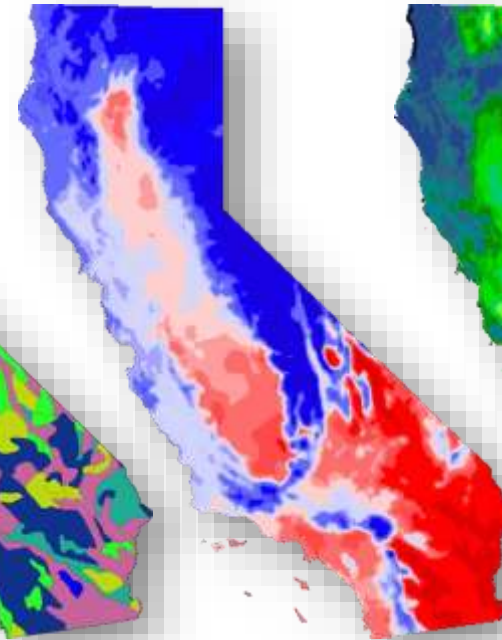

Precipitation

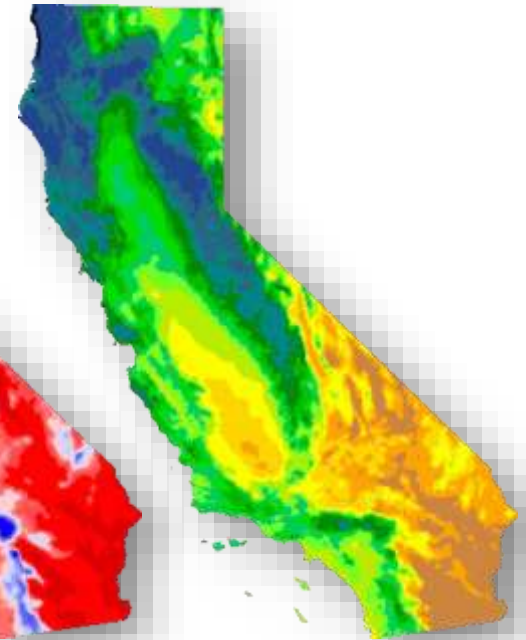

ASCI: Development approach

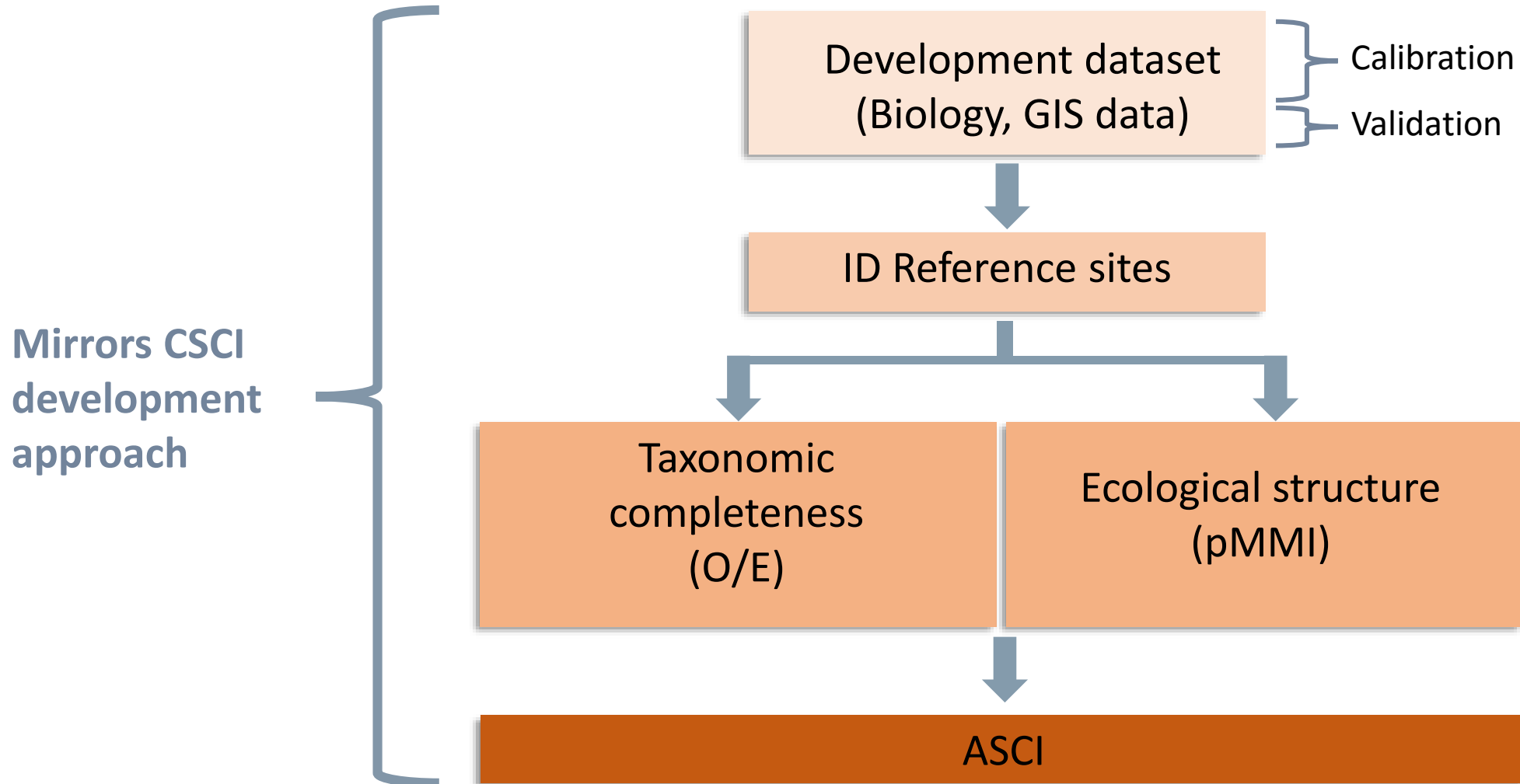

ASCI: Development dataset

2000 stations, 3800 taxa

- Stormwater Monitoring Coalition (SMC)
- Perennial Stream Assessment (PSA)
- Reference Condition Management Program (RCMP)
- Regional Monitoring Coalition (RMC)
- SWAMP

Algae taxonomy

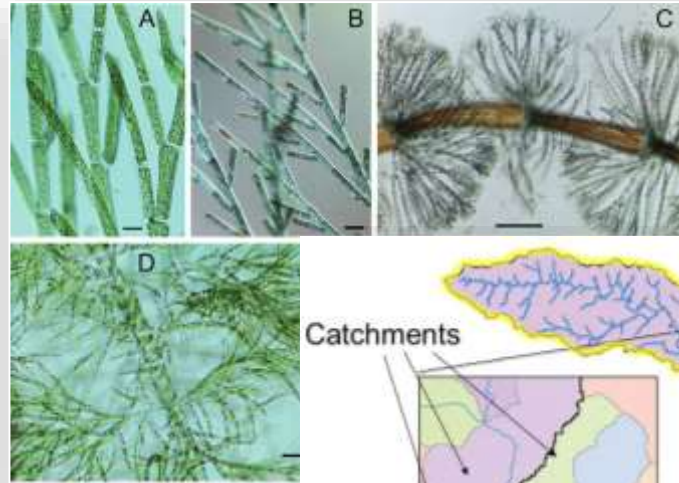

Spatial data

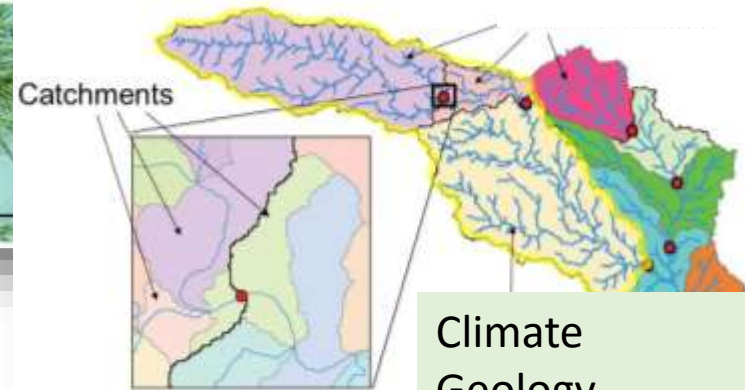

Climate
Geology
Elevation
Land cover
Road/dam/railroads

ASCI: Reference site selection

Metric	Scale	Threshold	Unit
% agriculture	1k, 5k, WS	3	%
% urban	1k, 5k, WS	3	%
% agriculture + % urban	1k, 5k, WS	5	%
% Code 21 (developed veg)	1k, 5k	7	%
	WS	10	%
Road density	1k, 5k, WS	2	km/km ²
Road crossings	1k	5	crossings
	5k	10	crossings
	WS	50	crossings
Dam distance	WS	10	km
% canals and pipelines	WS	10	%
Producer mines	5k	0	mines
W1_HALL (anthropogenic disturbance)	site	1.5	-

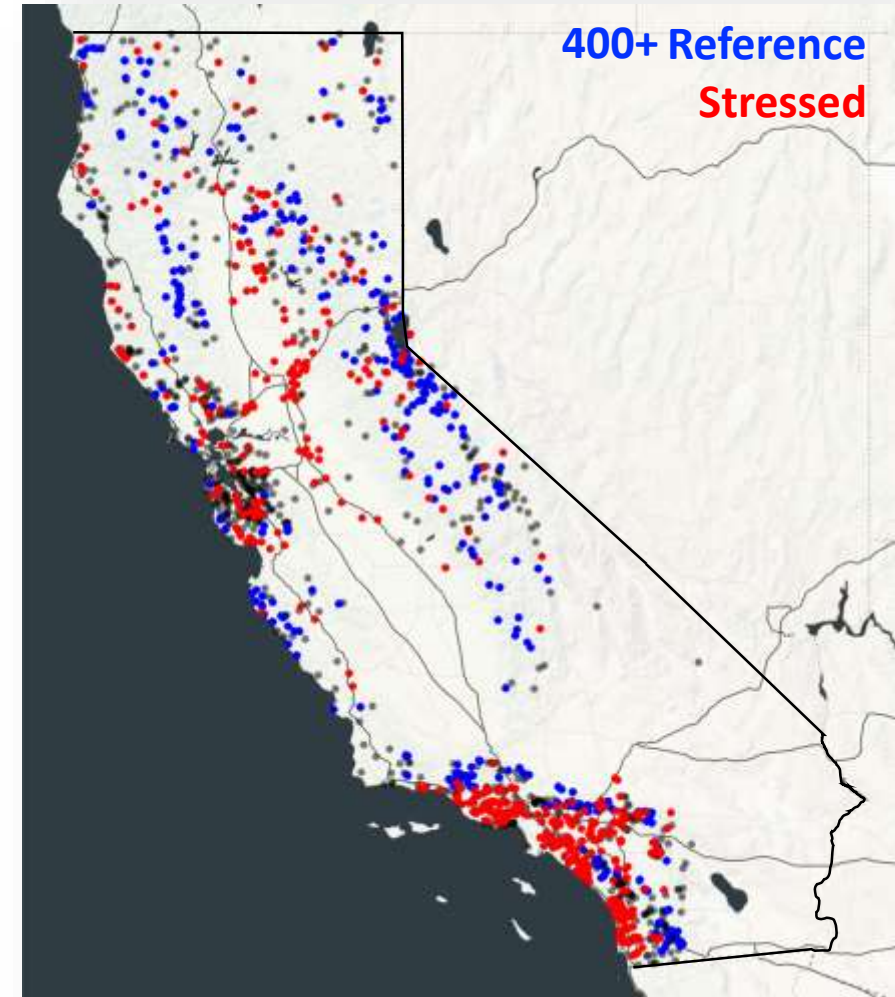

Geographic distribution of ALL sites

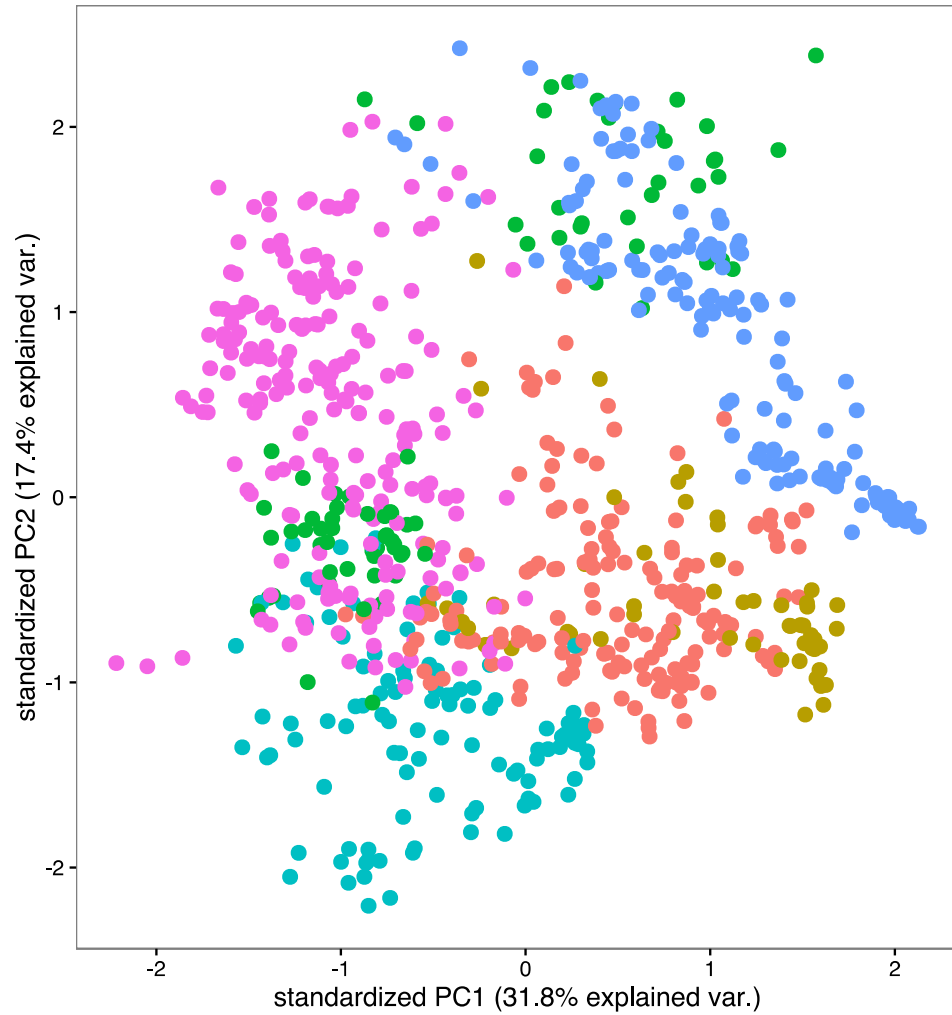

- Chaparral
- Central Valley
- Deserts Modoc
- North Coast
- South Coast
- Sierra Nevada



Geographic distribution of ALL sites

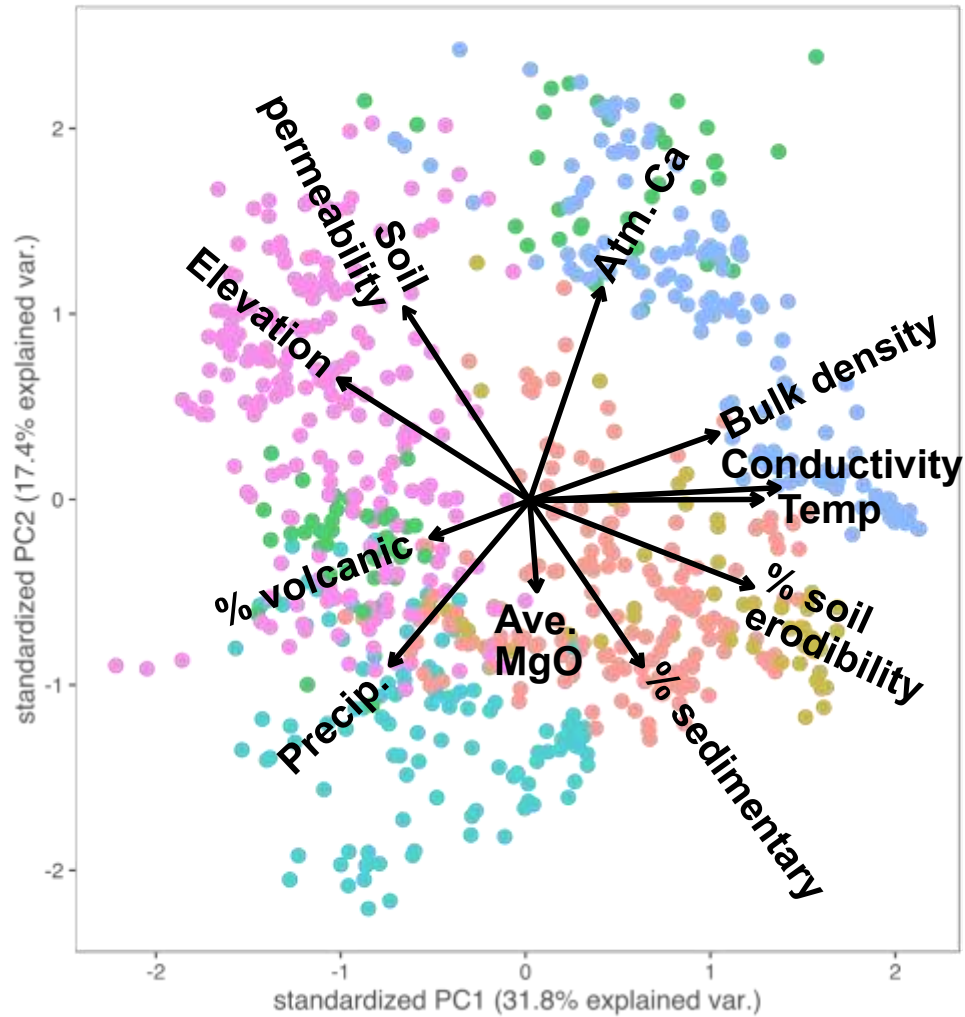

- Chaparral
- Central Valley
- Deserts Modoc
- North Coast
- South Coast
- Sierra Nevada



Geographic distribution of REF sites

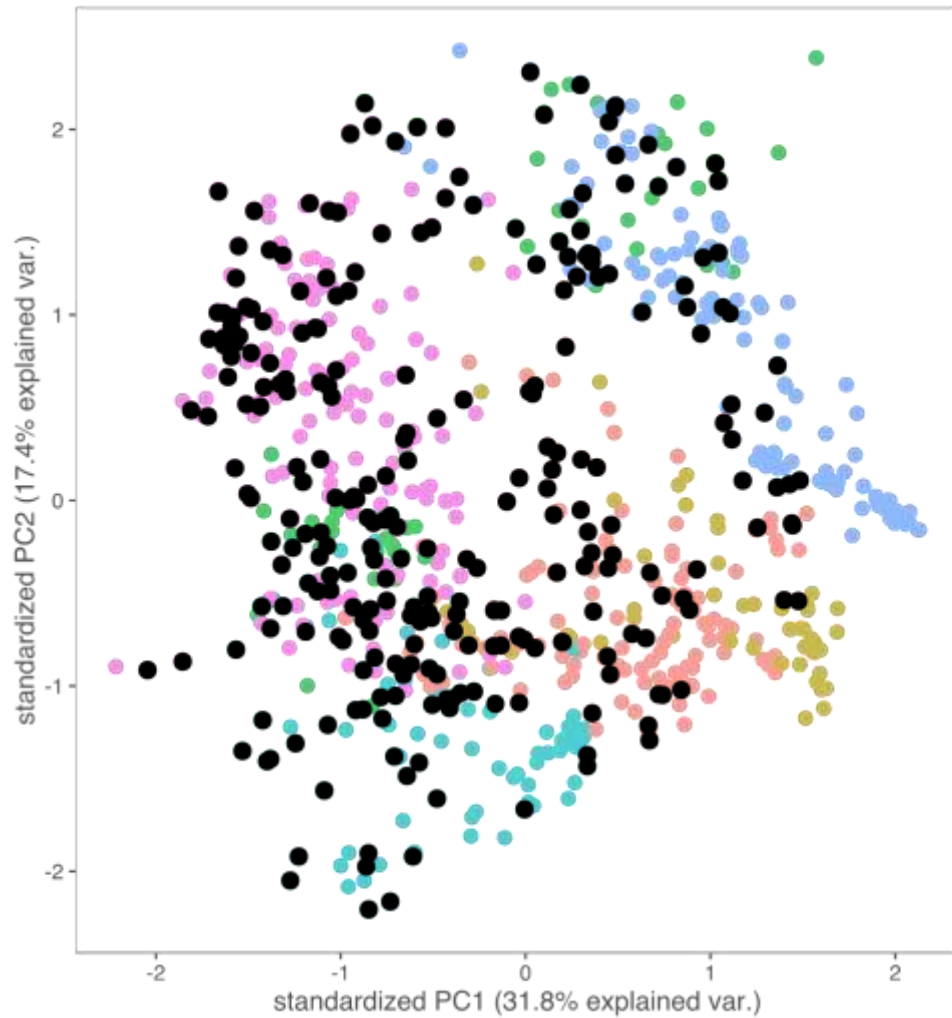

- Chaparral
- Central Valley
- Deserts Modoc
- North Coast
- South Coast
- Sierra Nevada
- Reference sites

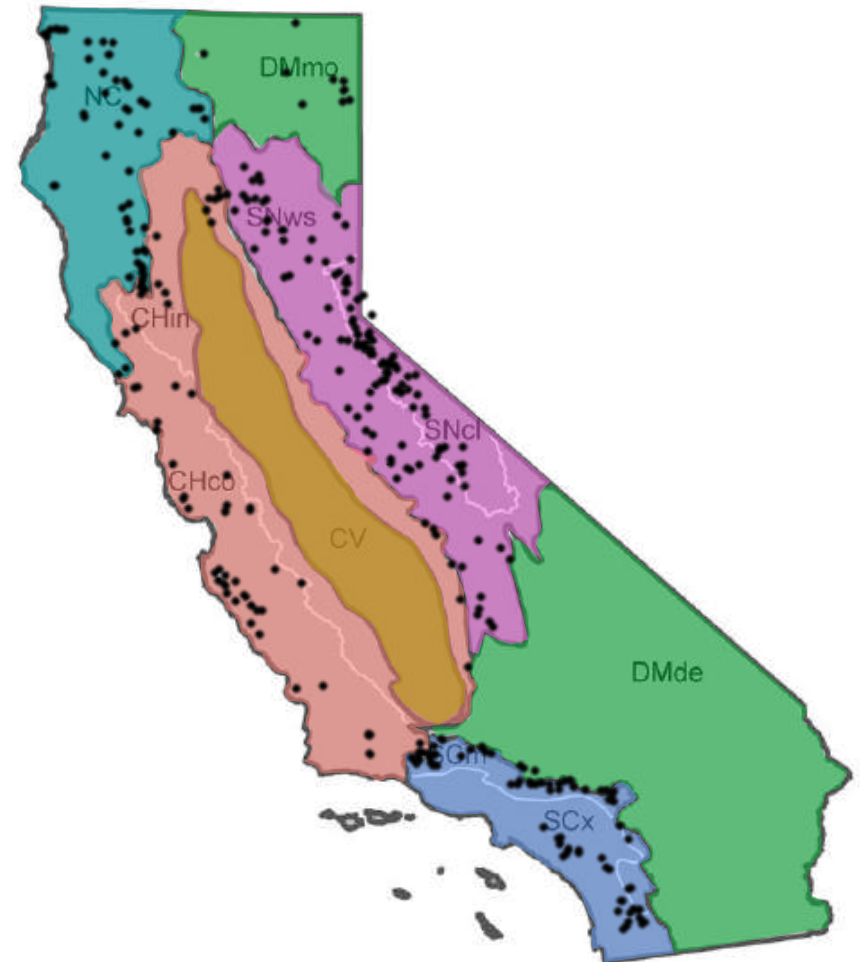

ASCI: two component index

Observed vs. Expected taxa distributions (O/E)

Diatoms



Softs



Cyanobacteria



Predictive Multi-Metric Index (pMMI)

Motility



Richness



N-loving

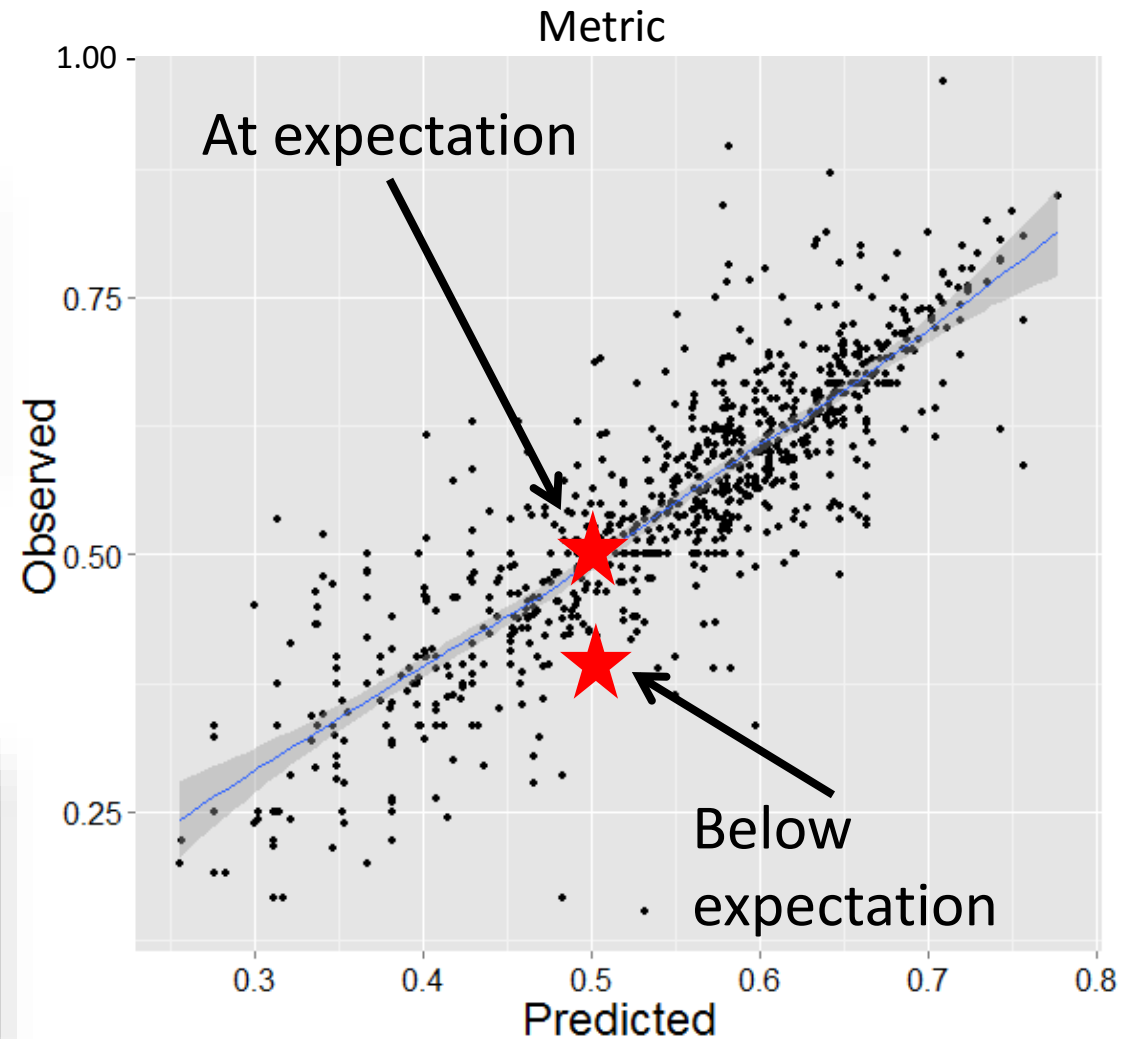

ASCI: evaluate performance

Performance aspect	How do we measure?
Sensitivity	Big differences between reference and stressed
Precision	Low SD for reference sites
Accuracy	Validation reference sites No bias from natural gradients, regions

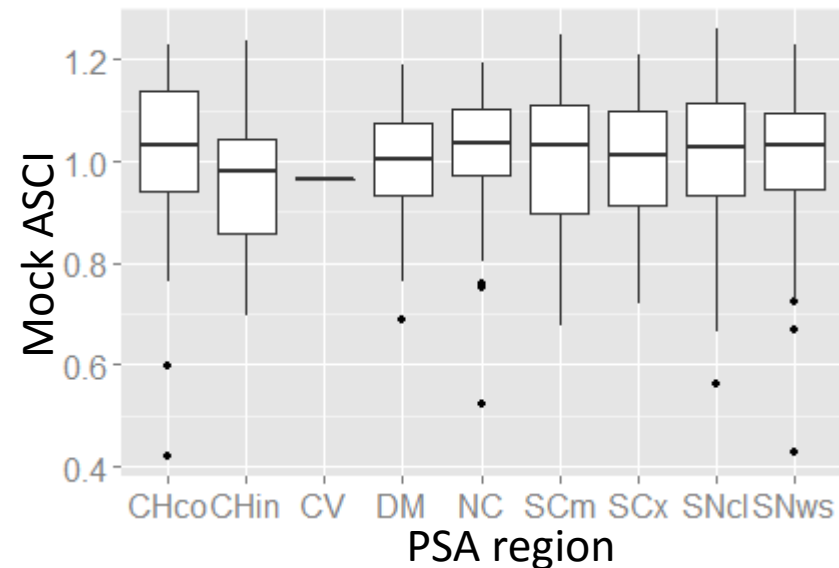
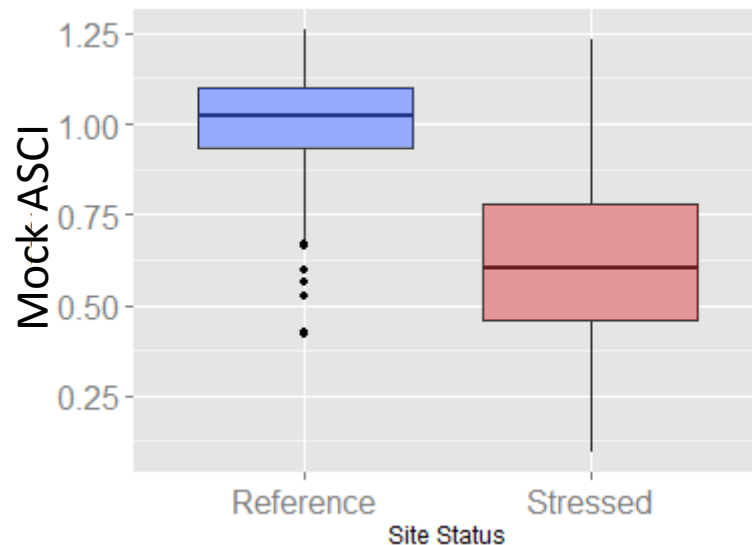

Products & Timeline

- ASCI scoring tool ← Update: Feb/March 2017
 - Predictive approach allows sites to be judged against site-specific expectations
 - Can be applied with consistent interpretation statewide
- Performance of index ← Oral presentation: June/July 2017
- Written report ← Report: September 2017
 - Guidelines for use
 - Development dataset
 - Calculator

Implementation support

Making algae tools accessible

- ASCI guidance documents (SOP)
- ASCI code
- Standardized Taxonomic Effort (STE) for algae

Future

- Incorporating Statewide Algal Index into online resources (SWAMP)



Future directions: Molecular methods

Capacity limitation:

- Few labs capable of performing algae taxonomic analyses
- Long wait times
- Expensive



Future directions: Molecular methods

Explore DNA-based approach to algae taxonomy

- Dozens of commercial and academic labs can perform analyses
- Illuminate previously overlooked species
- Inexpensive



Future directions: Molecular methods

DNA barcode approach

- Easily integrated into current field sampling protocols
- Sample stable (frozen) for months to years
- Pilot studies: ~200 Paired DNA/morphology samples collected during 2016

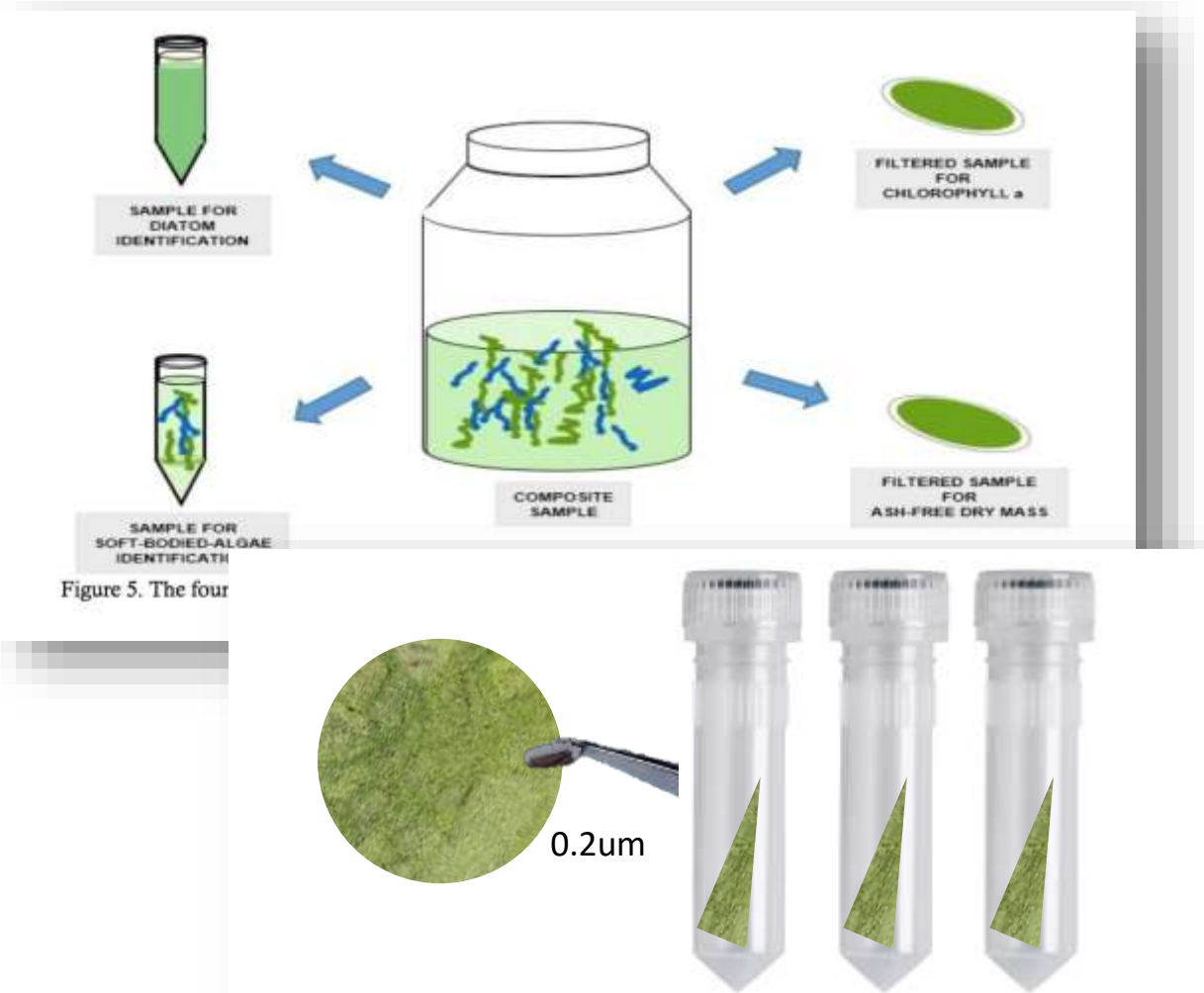

Future directions: Molecular methods

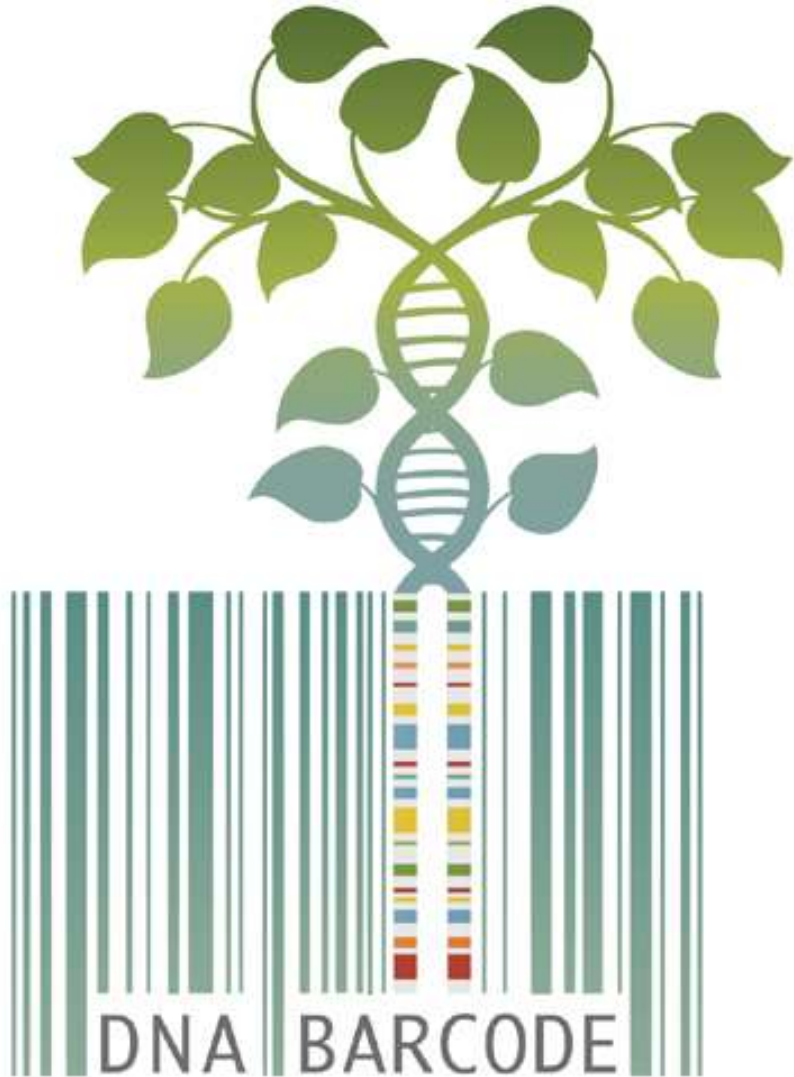

Key questions for pilot studies

1. How do morphology-based and DNA-based algae taxonomy data compare?
2. What new taxa are we identifying with molecular methods?
3. How well do algal indices perform with DNA data?

ETA: Early 2018

Summary: ASCI applications

- Algal Index will leverage years of algae taxonomy and environmental data
- ASCI will be integrated into in State and Regional ambient wadeable stream bioassessment toolkit
- Provide complementary information to CSCI and other biointegrity measures
- Support State Water Board combined biostimulatory and biointegrity amendments



Questions?

susannat@sccwrp.org

Acknowledgements

SWAMP/SWRCB	Pete Ode, Andy Rehn
Regional Boards	Rafi Mazor
CSUSM	Eric Stein, Martha
SMC	Sutula
DFW	Betty Fetscher



MEETING GOALS

- Provide an update on Water Board staff rationale for the combined biostimulatory and biointegrity projects
- Provide review and feedback on science supporting projects
 - Revised conceptual approach to science supporting the biostimulatory and biointegrity projects
 - Discuss work plans describing new technical elements
 - Update you on work in progress
- Describe proposed changes to Science Panel composition reflecting Biostimulatory and Biointegrity projects
- Describe timelines for review of technical work elements, including timing of stakeholder and science panel meetings.

STATEWIDE NUTRIENT OBJECTIVES PROGRAM: ORGANIZATION

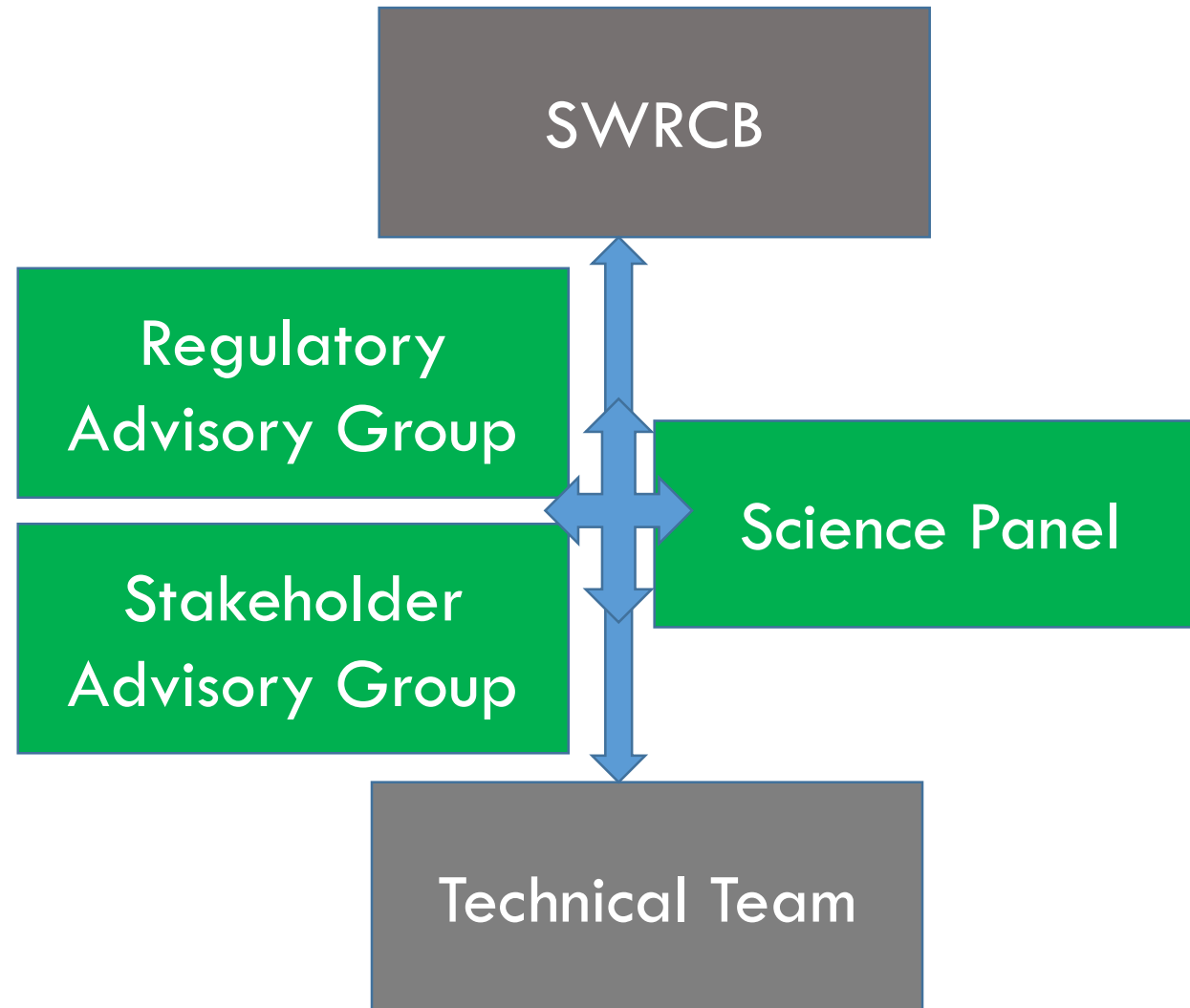

ROLE OF SCIENCE PANEL

- Provide independent technical review of policy development products
 - Includes the workplan and individual tasks
- Provide critical scientific insight based on extensive real world experience
 - Data gaps, alternative approaches, limits of interpretation
 - Potential management implications
- Like the SAG, their role is not approval
 - Its advisory

CONTEXT FOR TODAY'S DISCUSSION

- Both Biostimulatory (Nutrients) and Biointegrity Projects previously established Science Panels, in which the Advisory Groups:
 - Approved the desired attributes of Panel members
 - Vetted the candidates
 - State Water Board staff picked the final members.
- Previous Biointegrity Panel concluded work with review of CSCI
 - But we are now developing the Algal SCI
- Biostimulatory Panel work still in progress
 - Biological Condition Gradient

GOAL OF THIS AGENDA ITEM

- As we are combining Biostimulatory with Biointegrity policy, need to expand the “NNE” panel to include biointegrity expertise
 - Expand bioassessment and statistical modeling expertise
 - Maintaining a focus on eutrophication

Goal of today’s discussion is to discuss recommend membership of reformed “Biointegrity and Biostimulatory” Science Panel

PROPOSED PANEL MEMBERSHIP

- Stream Algal Ecology and Bioassessment: Jan Stevenson, Professor, Michigan State University **(NNE)**
- Benthic Invertebrate Ecology and Bioassessment: Charles Hawkins, Utah State University **(Biointegrity)**
- Stream Biogeochemistry and Ecology: Cliff Dahm, Professor Emeritus, University of New Mexico **(NNE)**
- Biogeochemical modeling approaches: Ken Reckhow, Professor Emeritus, Duke University **(NNE)**
- Statistical Approaches to Stress-Response Modeling: Lester Yuan, EPA Office of Science and Technology **(Biointegrity)**
- Nutrient Management/Implementation Strategies: Paul Stacey, Great Bay National Estuarine Research Reserve **(NNE)**

MEETING GOALS

- Provide an update on Water Board staff rationale for the combined biostimulatory and biointegrity projects
- Provide review and feedback on science supporting projects
 - Revised conceptual approach to science supporting the biostimulatory and biointegrity projects
 - Discuss work plans describing new technical elements
 - Update you on work in progress
- Describe proposed changes to Science Panel composition reflecting Biostimulatory and Biointegrity projects
- Describe timelines for review of technical work elements, including timing of stakeholder and science panel meetings.

PHILOSOPHY IN SCHEDULING AND AGENDIZING STAKEHOLDER ADVISORY GROUP MEETINGS VIS-À-VIS SCIENCE

- Four major stages of review
 - Workplan
 - Interim updates (by webinar if necessary)
 - Oral findings
 - Written report
- Written materials to review ~ 1 month in advance (if possible)
- Preview Science Panel charge questions and the science that will be presented to Panel in advance (no surprises)

PHILOSOPHY IN SCHEDULING AND AGENDIZING SCIENCE PANEL MEETINGS

- Same four stages of review
 - Workplan
 - Interim updates (by webinar if necessary)
 - Oral findings
 - Written report
- Public session (Day 1), Closed Session (Day 2), Report out (Day 2)
- Charge questions and written materials to review ~ 1 month in advance (if possible)
- Opportunity for advisory groups to present on issues or concerns during 1st day

Tentative Schedule for SAG Meetings:

January 2017 and ongoing – Webinars - implementation related work plans and updates

Feb/March 2017- Meeting (South)

- Interim Updates, Science Plan and Panel Charge

July 2017- Meeting (North)

- Oral findings (ASCI, BCG)

September 2017 – Meeting (South)

- Draft reports (ASCI, BCG)
- Oral findings (eutrophication synthesis statistical models linking to nutrients/OM)

November 2017 – Meeting (North)

- Revised reports (ASCI, BCG)
- Draft report (eutro synthesis & linkage to nutrients/OM)

Tentative Schedule for Science Panel Meetings

January 2017 – Webinar orientation

March 2017- Meeting (South)

- Science Plan
- Interim updates (ASCI, BCG, eutrophication synthesis)

October 2017 – Meeting (South)

- Draft reports (ASCI, BCG)
- Oral findings (eutrophication synthesis statistical models linking to nutrients and OM indicators)

January 2018– Meeting (South)

- Revised reports (ASCI, BCG)
- Written report (eutrophication synthesis and linkage to nutrients)
- Implementation Science

OTHER STAKEHOLDER MEETINGS OR PARTS OF MEETING CAN BE DEDICATED TO (POLICY) IMPLEMENTATION OPTIONS

- In process of organizing effort and conferring with Water Board upper management
- Will apprise advisory groups of schedule for this effort early 2017

QUESTIONS?

COMMENTS?

Jessie Maxfield

(916) 341-5484

JMAXFIELD@WATERBOARDS.CA.GOV